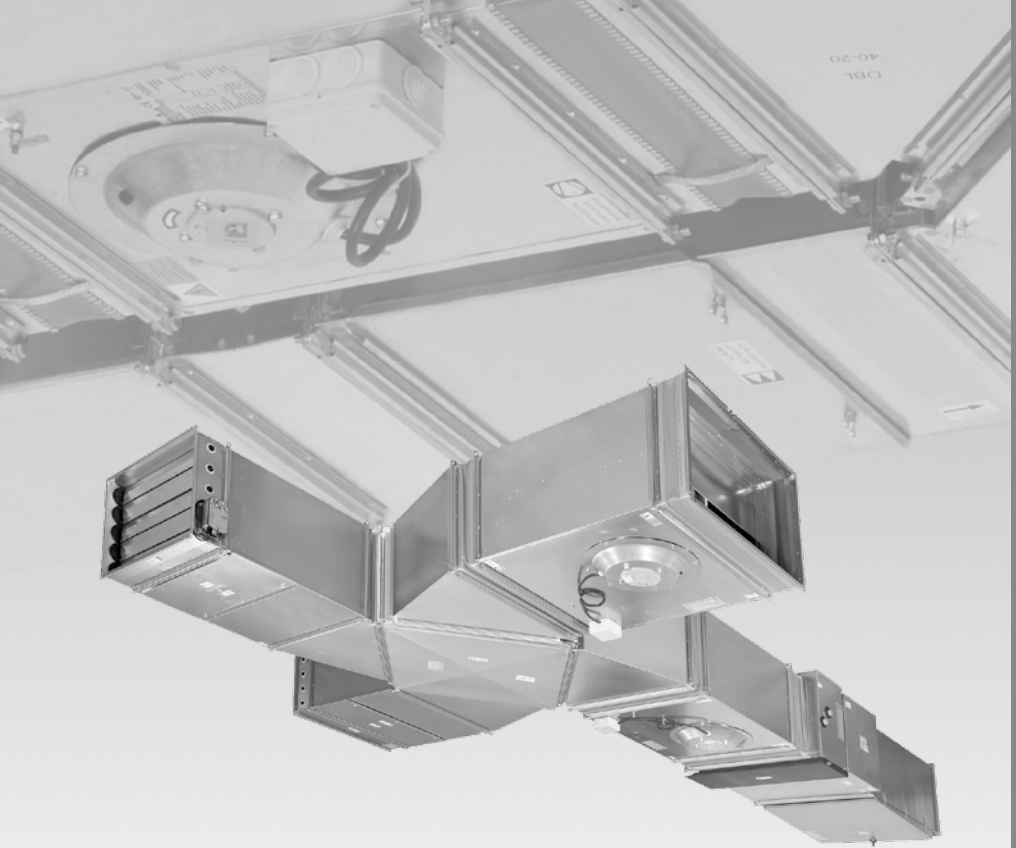


# REMAK



## Duct units

# VENTO SYSTEM



## Contents

<b>Radial duct fans with asynchronous motor</b>	RP, RPH, RO, RQ Fans.....	2
	RP Ex Fans.....	6
<b>Radial duct fans with EC motor</b>	RE Fans.....	7
<b>Fan output Controllers</b>	TRN Controllers.....	11
	TRRE, TRRD Controllers.....	13
<b>Exchangers</b>	EO, EOS, EOSX Electric heaters.....	15
	VO Water Heaters.....	19
	SUMX Mixing Sets.....	21
	CHV Water Coolers.....	28
	CHF Direct Coolers.....	29
<b>Heat Exchangers</b>	HRV Plate Heat Exchangers.....	30
	HRZ Plate Heat Exchangers.....	31
<b>Accessories</b>	KFD, VFK, VFT Filters.....	34
	LKR, LKS, LKSX, LKSF Blade Dampers.....	35
	SKX Mixing Chambers.....	36
	TKU Noise Attenuators.....	37
	EKP Drop Eliminators.....	37
	PK Pressure Dampers.....	38
	PZ Louvers.....	38
	DV, DK Elastic Connections.....	39
	EP, GK Flanges.....	39
	Humidification.....	40
<b>Additional information</b>	Disposal and Recycling.....	41

*Note: Installation instructions for the RF series of roof fans, ORP and ORe 5 controllers are available in separate documents.*

## Introduction

- Vento duct air handling units are manufactured in accordance with valid Czech and European regulations and technical standards.
- Vento duct air handling units must be installed and used only in accordance with this documentation. The manufacturer is not responsible for any damages resulting from use other than intended, and the customer bears the risks of such use.
- The installation and operating documentation must be available for the operating and servicing staff. It is advisable to store this documentation close to the Vento unit.
- When handling, installing, wiring, commissioning, repairing or servicing the Vento duct air handling units, it is necessary to observe valid safety rules, standards and generally recognized technical rules.  
**In particular, it is necessary to use personal protective work aids (e.g. gloves) because of sharp edges and corners when performing any handling, installing, dismantling, repairing or checking of Vento duct units.**
- All device connections must comply with the respective safety standards and regulations.
- Any changes or modifications to individual components of the Vento system which could affect its safety and proper functioning are forbidden.
- Before installing and using the Vento air handling units, it is necessary to familiarize yourself with and observe the directions and recommendations included in the following chapters.
- **The Vento duct air handling units, including their individual parts, are not intended, due to their concept, for direct sale to end customers. Each installation must be performed in accordance with a professional project created by a qualified air-handling designer who is responsible for the proper selection and dimensioning of components concerning their suitability for a given application. The installation and commissioning may be performed only by an authorized company licensed in accordance with generally valid regulations.**
- When disposing of components and materials, it is necessary to observe the respective environmental protection and waste disposal regulations. In case of final device liquidation, it is necessary to follow the policy of differential waste disposal. We recommend metal parts be scrapped and other parts be disposed of in accordance with separated waste regulations.
- Further information can be found in the „Duct Units“ Catalogue and in the AeroCAD planning software.

### Operating Conditions, poloha

Fans are designed for indoor and outdoor applications, and to transport air without solid, fibrous, sticky, aggressive, respectively explosive impurities.

For outdoor applications it is necessary to finish the fans with a protective coating (except rating plates). The transported air must be free of corrosive chemicals or chemicals aggressive to zinc and/or aluminium.

The RP, RO and RQ fans can work in any position. When positioned under the ceiling, it is advisable to situate the fan with its cup directed downwards to ease access to the motor terminal box. However, if transported air is over-saturated with moisture or if the risk of intensive steam condensation inside the fan exists, it is better to situate the fan's cup upwards while leaving enough servicing space for the motor terminal box. Fan protection, operating temperatures and other technical parameters for different types of fans are listed in a catalog of Vento duct units.

### Information and safety labels

All the basic information and safety labels are placed on the ventilator fan housing on the motor side, respectively attachment points of electrical connections (Figure 1), or for RPH fans – bonnet side and a connecting space under the lid.

Figure 1 – information labels



- Basic technical and operational information are shown on the fan nameplate
- For quick orientation and identification informative label "Fan" is located on the fan housing.
- On the fan housing on the side of the bowl / motor bracket, respectively, on the upper lid cap above the engine compartment and RPH connecting space, there is a label with a warning sign "Caution – Risk of electric shock."
- For proper orientation of the fan in the duct system there is the label "Flow direction" - a straight arrow.
- On the dish / engine bracket, eventually directly on the motor flange there is a label with the symbol of the direction of rotation.
- The grounding screws (near the terminal) are labeled grounding symbol
- On the reverse side of the terminal box cover there is a label "connection".

### Storage and Transport

#### Skladování

Fans must be stored in sheltered areas where:

- max. relative humidity does not exceed 85%
- condensation does not occur
- temperature ranges from -20 °C to +40 °C
- the device cannot be penetrated by dust, gases and caustic vapors or other chemical substances causing corrosion of components and equipment facilities.

#### Shipping and Handling

- Means for transportation, lifting and handling may only be used this purpose.
- Depending on the weight of the device can be carried by hand, the condition is the use of personal protective equipment.
- Do not pick up or carry fans using other parts than those which can be used for mechanical installation, respectively, suspension (flange connection carrier sheet). Especially components of electrical installation (box terminals) or hinged panels with impellers (these need to be always secured in the closed position when handling!)
- When performing any work take special care on the risk of falling and subsequent product damage or personal injury!

### Protection against Dangerous Contact with Non-Live Parts

On the sections that contain the electrical element, there are electrical installation boxes, into which the protective earth is led out. The inner and outer parts of the electrical sections are conductively connected. When installing the unit, take into account the requirements of the environment and the location of other electrical components around the unit, depending on the protective connection. If necessary, it is necessary to complete the protective connection for other sections of the unit.

### Mechanical Installation

- The fan must be checked carefully before its installation, especially if it was stored for a longer time. In particular it is necessary to check all parts and cable insulation for damage, and to see whether the rotary parts can rotate freely.
- It is recommended to insert the DV, respectively DK (placed at RQ fans inlet), elastic connections in front of and behind the fan.
- It is advisable to always place the KFD, VFK, respectively VFT metal grease air filter in front of the fan to protect the fan and duct against dirtying and dust fouling.
- If the fan is installed in such a way that persons or objects can come into contact with the impeller, the guard grid must be mounted.
- The fan must be suspended by separate suspensions so that no loading can be transferred to the elastic connections or connected duct. Against the transmission of vibrations to the building structure, it is necessary to hang the fans using noise and vibration damping hinges (eg "silent blocks")

### RP, RPH, RO, RQ Fans

**Figure 2** – Anchoring to the ceiling



**Figure 3** – Suspension using perforated strips

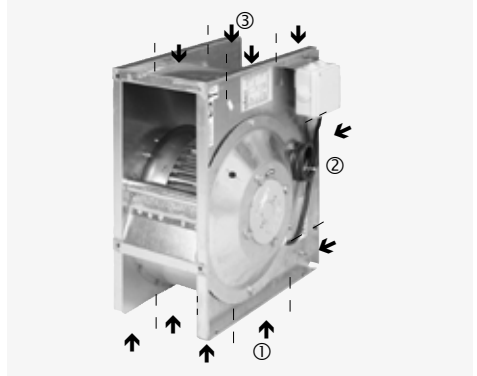


**Figure 4** – "Z" suspensions



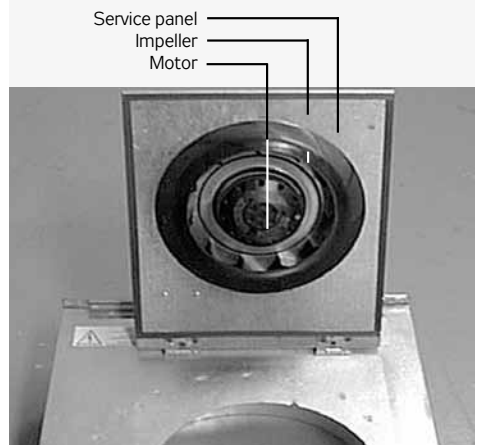
- Anchoring to the ceiling with steel anchors and suspension using threaded rods (see fig. #2), perforated galvanized strips (see fig. #3) or ancillary construction is recommended. Alternatively, using the so-called "A hinge" with integrated silentblock the respective load capacity (80 kg) and fixing steel rivets (Fig. 4) or on the supporting construction.
- The RQ fans are provided on three sides with anchoring holes to be anchored to the foundation in one of three possible positions ①②③ (Figure 5). The RQ fans can be anchored with four anchoring bolts; however, we recommend using silent-blocks to eliminate the transfer of vibrations.
- Before installation, paste self-adhesive sealing on to the connecting flange face. To connect individual parts of the Vento system, use galvanized screws and nuts M8 (M10 only for 90-50 and 100-50 sizes). It is necessary to ensure conductive connection of the flange using fan-washers placed on both sides, at least on one flange connection.
- To brace the flanges with a side longer than 40 cm, it is advisable to connect them in the middle with another screw clamp which prevents flange bar gapping.

**Figure 5** – Anchoring holes



- For RO fans with hinged panel impeller (Figure 6), it is necessary to tighten the screws thoroughly cover in the closed position..

**Figure 6** – Hinged service panel

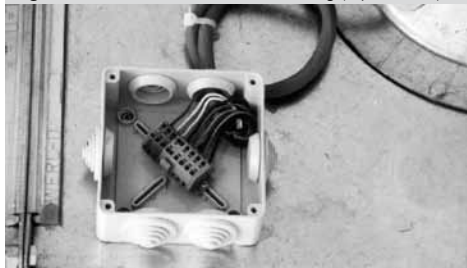


### Wiring

- The wiring can be performed only by a qualified worker licensed in accordance with national regulations.
- The fans can be equipped with two types of terminal boxes:
  - a) An all-plastic terminal box fixed with screws to the fan casing, and equipped with WAGO terminals; max. cross-section of connecting conductors 1.5 mm<sup>2</sup> (see fig. #7).
  - b) A plastic terminal box fixed with screws to the motor stator, and equipped with screw terminals (see fig. #8).
- RPH fan has terminal box (IP 40) located under the cover panel (Figure. 9).

## RP, RPH, RO, RQ Fans

**Figure 7** – terminal box on the fan casing (3-ph. motor)



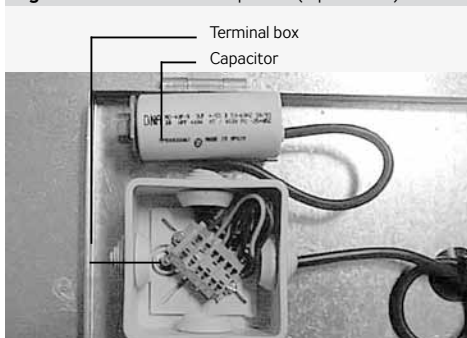
**Figure 8** – Plastic terminal box on the motor stator



**Figure 9** – Internal wiring arrangement (RPH series fan)



**Figure 10** – Terminal box/capacitor (1-ph. motor)

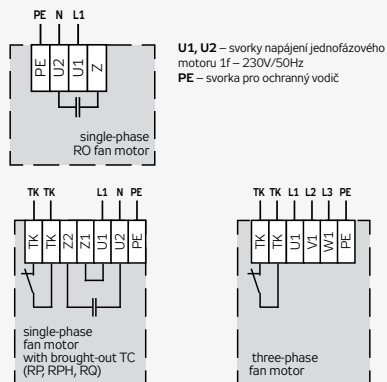


For single-phase fans a capacitor mounted outside the box terminals must be checked (Fig. 10).

■ The wiring connection to the terminals can be performed following the marking on the motor cables, description of terminals or the label on the terminal box lid (see fig. #11).

■ Třífázové motory musí být vždy zapojeny (Y, D) podle

**Figure 11** – Wiring diagram



údajů v technických parametrech, resp. podle údajů na štítku motoru (předzapojeno od výrobce).

■ Schéma zapojení ventilátoru s předřazenými prvky (ochranné relé, regulátory, řídicí jednotky) jsou součástí Instalačního návodu.

■ The following cables are recommended to connect fan motors:

H05VVH2 – F 2Ax0,75 – okruh termokontaktů

CYKY – J 3x1,5 – napájení jednofázových motorů

CYKY – J 4x1,5 – napájení třífázových motorů

### Motor Protection

As standard, the permanent monitoring of internal motor temperature is applied in all motors. The limit temperature is monitored by thermal contacts (the TK-thermo-contacts) situated in the motor winding. The thermo-contacts are miniature thermal tripping elements which are arranged either in series with the power supply (only for single-phase fans RO) or involved in a separate circuit and taken to the terminal (RO three-phase fans and all fans RP, RQ, RPH). Thermocontacts are then automatically being connected to the protective contactor circuit protect the motor against overheating (damaging) due to phase failure, forced motor braking, current protection circuit breakdown or excessive temperature of transported air. The thermal protection by means of thermo-contacts is complex and reliable providing they are correctly connected. This type of protection is essential especially for speed controlled and frequently

### RP, RPH, RO, RQ Fans

started motors and motors highly thermally loaded by hot transported air.

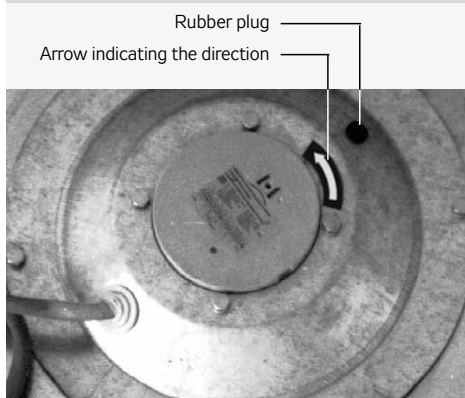
Therefore, the fan motors cannot be protected by conventional overcurrent protection elements!

The thermo-contact rated loading is: 6A / 250V / 50 Hz /  $\cos \varphi 0,6$

#### Activation and Start-up

- The fan can be started after its mounting into the duct system for which it has been designed; preferably fully throttled by closing either the intake or discharge to avoid its overloading! (Applicable for fans with non-working area). The fan is loaded by increasing the air flow, i.e. by releasing the throttling.
- After starting the fan with three-phase motor, the right direction of the impeller rotation must be checked following the direction of the arrow on the fan. To do so, remove the rubber plug from the inspection opening in the fan cup (see fig. #6). The RP, RPH, RQ and RO fans' impellers rotate always to the left, i.e. counter clockwise (looking through the inspection opening).
- After starting the fan, the current must also be measured, and it must not exceed the maximum allowed current  $I_{max}$ , stated on the rating plate. If the measured values exceed the given current value, it is necessary to check the duct

Figure 12 – Rubber plug location



system regulation.

- With the exception of single-phase fans RO which use thermal protection functioning automatically interrupting the power (and operation), all ventilators RP RPH, RQ and three-phase RO fans are equipped with thermo-contacts situated in the motor winding; they are connected to the TK terminals. If the motor gets too hot, the thermo-contact will open. The thermo-contact must be connected to the control or regulating system (e.g. control unit, TRN controller or STE, STD relay) which is able to evaluate the failure, and protect the motor against unwanted thermal effects. The proper function of the controller must ensure that after getting cold and the thermo-contact closing, the motor

cannot be spontaneously started. Before restarting the fan, it is necessary to check the duct system regulation, electrical parameters of the motor and the entire wiring.

- If the fans are operated without connection to this protection, our warranty for the damaged motor will become void.
- For single-phase fans RO with automatic thermal protection it is necessary to be very careful and always disconnect power when checking, respectively, during service works to avoid injury when the fan starts up automatically after cooling.

#### Operation, Maintenance and Service

During operation it is necessary to check proper functioning of the fan, its smooth running, to keep it and its surroundings clean, and load the fan only within the range given by its output characteristics.

If a failure occurs, make sure that the power supply is disconnected, and check the fan for foreign objects inside, and free rotation, or if the fan is not overheated. If the fan does not run after it has been restarted, the following procedures must be followed depending on the protection system used:

- **If the fan is protected by STE or STD relays:**  
Turn the fan on/off using the switch on the remote controls of the controller.
- **If the fan is protected by a TRN controller:**  
vypnout a zapnout ventilátor vypínačem na vzdáleném ovládaní regulátoru.
- **If the fan is protected by the control unit:**  
Press the unblocking button on the control unit (the horn symbol), and restart the unit.  
If the fan does not start: Check the wiring, and measure the motor winding impedance. If the motor is damaged, contact your supplier.

**Warning! When performing any maintenance or repairs, the device must always be disconnected from the power supply! To ensure voltage-free state, the device must be provided with a stand-alone and lockable switch (or with a control unit equipped with such a switch).**

**Wiring diagram fan with front-end elements (protective relays, controllers, control units) are included Installation manual.**

### Use of RP fans in Ex design

Explosion-proof, fully controllable, low-pressure, radial fans RP \* - \* / \* - \*\* Ex (hereinafter referred to as RP Ex) can be used universally, from simple ventilation to complex air-conditioning systems for complex air treatment. Due to the special construction preventing the formation of mechanical ignition sparks according to the standards ČSN EN ISO 80079-36, ČSN EN ISO 80079-37, ČSN EN IEC 60079-0 and the secured design "e" with the level of protection "eb" of the electric motor according to ČSN EN 60079 -7 fans are predestined for use in environments with a risk of explosion of gases and vapors..

### Operating Conditions, Position

- RP Ex fans are approved by the Notified Body No. NB 1026, Physical-Technical Testing Institute, s.p., Ostrava-Radvanice. The fans are designed for indoor and outdoor use. It is used for air transport without solid, fibrous, sticky, aggressive admixtures. The air must not contain chemicals that cause corrosion of zinc, copper and aluminum. The permissible supply air temperature is between -20 and +40 °C.
- In terms of classification of areas with a risk of explosion ČSN EN 60079-10-1, the fans are designed for the environment and for the extraction of air from the environment zone 1 or zone 2.
- Explosion-proof electric motors of RP Ex fans in the secured version "eb" belong to group II according to the standard ČSN EN IEC 60079-0 and are marked with a non-explosive symbol:
  - **II 2G Ex eb IIC T3 Gb.**
  - RP Ex fans are marked with a non-explosive symbol.
  - **II 2 / 2G Ex h IIB+H<sub>2</sub> T3 Gb / Gb.**
  - The fans can operate in any position.

### Warning!

Detailed safety and operating information on RP Ex fans is issued in a separate document, available at [www.remak.eu](http://www.remak.eu)

**"RP radial fans in Ex design, type: RP \* - \* / \* - \*\* Ex – Installation and operating instructions"**



### RE Fans

#### Operating Conditions, poloha

Fans are designed for indoor and outdoor applications, and to transport air without solid, fibrous, sticky, aggressive, respectively explosive impurities. For outdoor use, the fan must be provided with protective finish coat (with the exception of the production of labels) and possibly the roof. Air mass may not contain chemicals that corrode or degrade zinc, aluminum and plastics.

RE fans can work in any position. When placed under the ceiling, it is appropriate, for better access to the terminal and engine to mount fan opening panel (bowl) engine facing downwards. If the air is saturated with moisture or threatens inside the fan intensive steam condensation, it is suitable to mount the fan opening panel (cup) of the motor upwards while maintaining service access to the terminal block and the motor.

Specific operational and technical parameters of individual types of fans are listed in a catalog of Vento duct units.

**Warning! Due to the use of EC motors with permanent magnets it is not possible to operate either storage or transport RE fans at ambient temperatures below -40 ° C!**

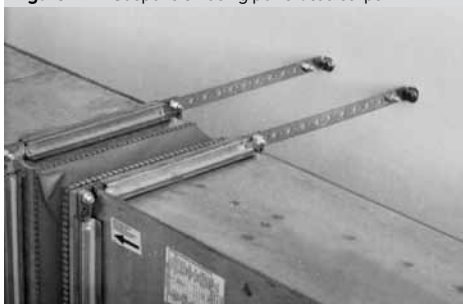
#### Mechanical Installation

- The fan must be checked carefully before its installation, especially if it was stored for a longer time. In particular, it is necessary to check all parts and cable insulation for damages, and to see whether the rotary parts can rotate freely.
- It is recommended to insert the DV elastic connections in front of and behind the fan.
- It is advisable to always place the KFD, VFK, respectively VFT metal grease air filter in front of the fan to protect the fan and duct against dirtying and dust fouling.
- If the fan is installed in such a way that persons or objects can come into contact with the impeller, the guard grid must be mounted.
- The fan must be suspended by separate suspensions so that no loading can be transferred to the elastic connections or connected duct. The fan suspensions must always include attenuation and anti-vibration elements (e.g. silent blocks).
- Anchoring to the ceiling using steel anchors and "Z" suspensions of suitable load capacity (e.g. suspensions with integrated silent blocks of 80 kg load capacity) riveted to the fan casing or ancillary construction is recommended.
- Before installation, paste self-adhesive sealing onto the connecting flange face. To connect individual parts of the Vento system, use galvanized screws and nuts M8 (M10 only for 90-50 and 100-50 sizes). It is necessary to ensure conductive connection of the flange using fan-washers placed on both sides at least on one flange connection.
- To brace the flanges with a side longer than 40 cm, it is advisable to connect them in the middle with another screw clamp which prevents flange bar gapping.
- For RE fans with hinged panel the impeller cover screws cover should be carefully tighten in the closed position.

Figure 13 – Anchoring the fan



Figure 14 – Suspension using perforated strips



#### Wiring

- The wiring can be performed only by a qualified worker licensed in accordance with national regulations.
- Electrical installation is completed according to the type of fan either with a separate box with IP 44 / IP 54 for power connection and a box with IP 44 for control connections (Figure 15) or double-segment terminal box built under a cover on the body of the motor (IP 54) (Figure 16).
- Motor electronics ensures even three-phase fan correct direction of rotation regardless of the phase sequence.
- Small fan types have a speed indicator which allows tracking of fan speed. Larger models have an output potential free relay contact for fault reporting. See diagrams (Figure 17).
- To connect fan motors following cables are recommended, for example:  
CYKY – J 3x1,5 – single-phase motor supply  
CYKY – J 4x1,5 – three-phase motor supply  
JYTY – O 2x1 – control signal 0–10 V, and/or JYTY – O 3x1 using +10 V power source from the fan and connecting potentiometric ORP controller.

*Note: If 20 m in length or less shielded cable is not required and can be used eg. H05VV-F 2x1, respectively. H05VV-F 3x1) H05VVH2 - F 2Ax0,75 - EC motor fault (if available)*

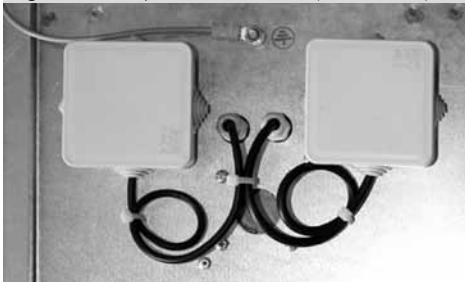
To avoid electromagnetic interference sufficient distance from powerlines control lines and motor lines must be guaranteed. The length of the control cables must be max. 30

## RE Fans

**Figure 15** – double-segment terminal box



**Figure 16** – 2 separate terminal boxes(motor/cables)



m, 20 m lines must be shielded. When using a shielded wire must be connected to the protective shielding conductor on only one side, i.e. only on the device (which must be as short as possible and have low inductance).

### Motor protection

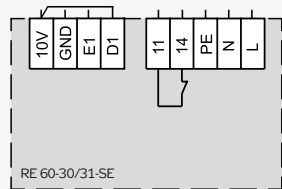
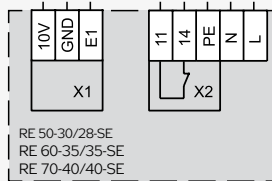
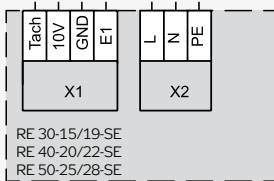
As standard all motors provide permanent automatic checking of internal temperature. EC motor electronic controls operation of the fan to avoid damage in case of incorrect operating conditions (blocked, repeated overheating, phase loss), the fan stops and or indicates a failure (models equipped with a fault relay). Fan operation resumes after activating the protective functions and the removal of the subsequent problems, so chilling. etc.

**Warning! Application of this operational behavior (not-indicated shutdown) must be evaluated in the context of the project and HVAC control system. When checking, or performing fan service works it is necessary always disconnect the power supply to avoid injury when the fan starts up automatically after cooling.**

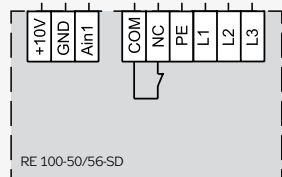
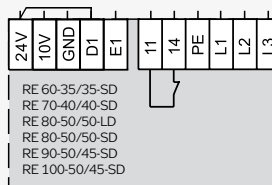
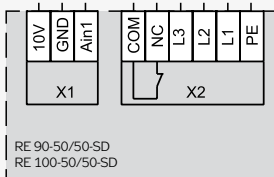
*Note: RE 50-30/28-SE, RE 60-35/35-SE, RE 70-40/40-SE, RE 90-50/50-SD and RE 100-50/50-SD fans have, as standard, built-in Modbus communication (terminals A, B, in the X1 junction box X1 - control circuits). Modbus communication within RE fan series is not used by default. Terminal description is therefore not included in the above wiring diagrams. Modbus communication is used only for the service purposes (and/or for special fan control methods).*

**Figure 17** – wiring according to types

### a) Single-phase fans



### a) Three-phase fans



### Terminals description (summary):

**L1, L2, L3** – power supply

**N** – neutral conductor

**PE** – protective conductor

**11, 14** – Summary fan failure (loading of the 250 V AC, 2 A contact)

**NC, COM** – Summary fan failure (loading of the 250 V AC, 2 A contact)

**D1** – digital input (on/off)

**E1** – input 0–10 V DC

**Ain1** – input 0–10 V DC

**10V** – voltage source 10 V DC

**24V** – voltage source 24 V DC

**GND** – ground

### RE Fans

See complete operating manuals of EC motors)

#### Fan output control

- Changing the speed a performance of RE fans can be fully controlled. Speed changes via an analog input control voltage (0-10 V DC), while fan control (engine electronics) provides constant activating" voltage of 10 V DC or it is possible to control the fan via an external 0-10 V signal from a complex control system.
- Potentiometric ORP controller (for manual fan control) is available as an accessory.
- Using voltage 0–10 V, respectively using potentiometric ORP controller it is possible to control two or more fans connected together in parallel to control signal (max. - according to max. possible load supply voltage of 10 V) but there always must be "activating" voltage of 10 V applied only from one source or fan (may not be connected to other +10 V fan output), see Figure 18.
- The control voltage is also necessary to use to stop the fan from operating (standard and disconnecting power) - see above Operating conditions.
- For the course of speed control (the flow) of the fan according to the level of the input signal, see Figure 19 and Table 1.

#### Activation and Start-up

- The fan is being started when fitted to the duct network, for which it was designed, applying the supply voltage and control signals – refer to control the fan power.
- The loading takes place by increasing the fan flow, i.e. throttling release.

Figure 19 – the course of fan power control

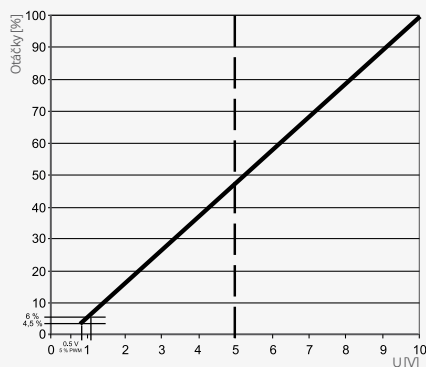
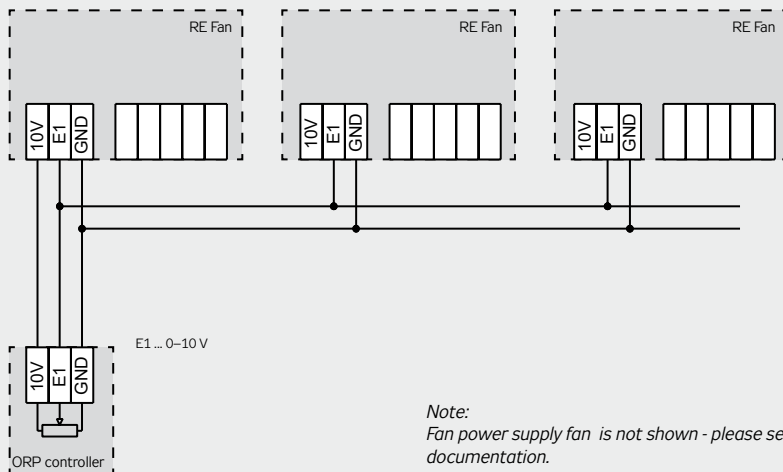


Table 1 – The course of fan power control

DC Control Voltage [V]	Operation State	Fan Speed (%)
0-1 <sup>(1)</sup>	STOP	0
>1 <sup>(1)</sup>	CHOD	viz obr. 1
10	CHOD	100

Figure 18 – Connection of ORP controller to RE fans



Note:  
Fan power supply fan is not shown - please see fan documentation.

(1) in the area around the level of the control signal (1 V) it is necessary to count with hysteresis switching on/off

- After starting the fan, it is appropriate to measure current, which can not exceed +5% maximum allowed current  $I_{max}$  on the nameplate. We recommend measuring the current using device enabling measurement of the effective value of the non-sinusoidal current (true RMS).
- If there are higher values of current, it is necessary to check regulation of duct network or the smooth rotation of the impeller.

### Operation, Maintenance and Service

- During operation it is especially necessary to oversee the proper fan operation, smooth running, take care of the cleanliness of the fan and its surroundings, burden the fan only within the range of its power characteristics.
- When removing any faults it is necessary to check the control voltage, which must be higher than 1 V<sup>(1)</sup>.
- Even if then the fan does not run, it is necessary to carefully examine whether the mains voltage is disconnected, and check the fan for foreign objects and if the fan rotates freely. If, after switching (pause min. 60 sec), the fan does not run again, we recommend you contact our service department.

**Warning! When performing any maintenance or repairs, the device must always be disconnected from the power supply!**

**After disconnecting the mains voltage, dangerous charge may occur at the terminals. Wait min. 5 min before opening the terminal.**

**To ensure voltage-free state, the device must be provided with a stand-alone and lockable switch (or with a control unit equipped with such a switch).**

---

(1) in the area around the level of the control signal (1 V) it is necessary to count with hysteresis switching on/off

### TRN Transformer Controllers

#### Operating Conditions, poloha

These controllers are intended for indoor applications in a dry, dust and chemical-free environment. They are designed for normal environmental conditions in accordance with ČSN 33 2000-1 ed.2 (IEC 364-3).

- Degree of protection: IP 20
- Permissible ambient temperature: +5 °C to +40 °C
- Position: always vertical or horizontal.

The controllers can be situated on a wall, air-handling duct or ancillary construction. They can be mounted on A and B combustibility grade materials in accordance with the ČSN EN 13 501-1 and, ČSN 73 0823 standards.

The installation must be performed considering the weight of the controller, easy wiring, service access, and free cooling openings. The controller casing is provided with ventilation openings, which must not be covered.

#### Installation

- The installation and commissioning can be performed only by an authorized company licensed in accordance with valid regulations.
- The controller must be checked carefully before its installation, especially if it was stored for a longer time. In particular, it is necessary to check all parts and cable insulation for damage.
- It is advisable to place the TRN output controller close to the fan, e.g. in a machine room, in the ceiling, etc. The controller can be placed on a wall, air-handling duct or ancillary construction. With regard to its weight, the controller is installed in three steps.
  - First, fix the base with 4 screws  $\varnothing$  6 mm.
  - Hang the controller supporting plate, including wiring, on the base, and secure it with a screw.
  - Finally, fix the controller cover.
- The installation must be performed considering the weight of the controller, easy wiring, barrier-free service access, and free cooling openings.
- As the controller contains sensitive electro-mechanical parts, take care and keep the controller interior clean. Especially, it is necessary to avoid the controller being contaminated with dirt from a construction site (dust, sand, plaster, etc).
- The remote control can be situated at any distance from the controller, and mounted on a wall at the operator's location.

#### Wiring

The wiring can be performed only by a qualified worker licensed in accordance with national regulations.

- Cables for the power supply, fan motors connection and control are led through plastic grommets, and connected to the WAGO terminals in the lower part of the controller casing.
- The wiring connection must be performed in accordance with the description inside the controller (fig. #24, page #15).
- To make replacing the fuse easy, free access and the necessary handling space must be provided.

**Table 2 – TRN fuses assignment**

Controller	Phase	Current
TRN 2E	1 × T 3,15 A / 250 V	160 mA
TRN 4E	1 × T 6,3 A / 250 V	160 mA
TRN 7E	1 × T 8,0 A / 250 V	160 mA
TRN 2D	3 × T 3,15 A / 500V	160 mA
TRN 4D	3 × T 6,3 A / 500 V	160 mA
TRN 7D	3 × T 8,0 A / 500V	160 mA
TRN 9D	3 × T 10 A / 500 V	160 mA

- Table 6 shows the installation of various types of controller fuses.
- Each fan must be connected to a separate controller. If one output stage for two fans (inlet, outlet) is needed, it is possible to control both controllers by one remote governor. For more detailed information, refer to the operating instructions of individual controllers.
- As standard, the TRN controllers are equipped with integrated fan motor protection. The TK terminals in the controller serve to interconnect the TK terminals of the fan motor thermo-contacts.
- If the fan motor is overheated due to overloading or emergency, the thermo-contacts will open and the controller will stop the fan. When the motor cools down, and the failure is removed, the fan can be restarted from the zero position on the remote governor.
- The TRN controllers enable remote (external) starting/stopping of the fan independently of the governor. This function can be controlled by connecting or disconnecting the circuit between the PT1 and PT2 terminals. This feature can be used to start the fan by an external switch (thermostat, rheostat, hydrostat, auxiliary contact, etc...).
- After connecting the controller, the current must be measured, and it must not exceed maximum allowed value in any output stage. The maximum current value is stated on the rating plate as a numerical part of the type code of the controller (e.g. TRN7D means  $I_{max} = 7A$ ).
- If the current values are higher, check whether the controller is connected to the appropriate fan; the rated current of the fan should be lower or equal to  $I_{max}$  of the controller.
- If the measured current value still exceeds the maximum permissible value even though the connected fan complies with the above-mentioned criteria, immediately check the duct system regulation. The fan is probably operated in a so-called forbidden (non-working) area of the fan output characteristics. The proper current value can be reached by air flow throttling. If the current value does not drop, it is necessary to check the electrical parameters of the entire wiring.
- The installation must be performed in accordance with the project (resp. Installation Manual). Before putting the controller into operation, an inspection of the wiring must be performed..

## TRN Transformer Controllers

### Blocking of Output Stages

For each output stage which can be blocked (1, 2, 3) there serves one connection – "jumper". A combination of their states assigns blocked output stages. Their settings are independent; however, in practice the lowest stages are blocked, usually dependently, as indicated in table 3.

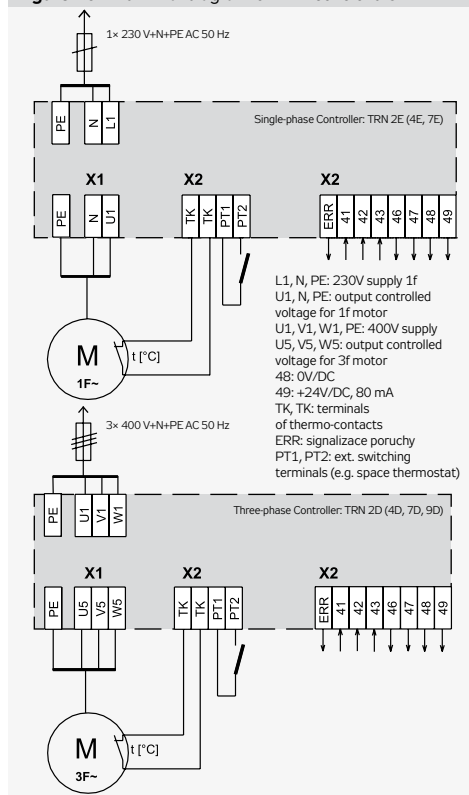
**Table 3** – Blocking of output stages

Blocking of output stages	Jumper" settings		
	J1	J2	J3
No blocking	ON	ON	ON
st. 1	OFF	ON	ON
st. 1 + st. 2	OFF	OFF	ON
st. 1 + st. 2 + st. 3	OFF	OFF	OFF

ON ... means connected state, OFF ... means disconnected state

### Wiring

**Figure 20** – Terminal diagram of TRN controllers



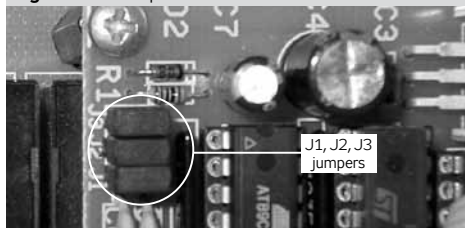
**Table 4** – Stavý regulátoru vs. řídicí vstupy

Speed	49 41	49 42	49 43
Speed 1			
Speed 2			
Speed 3			
Speed 4			
Speed 5			
STOP (Ot. 0)			
Stop/Reset			
Start			

Contact dimensioning 24V/DC, 0,1A

*Note: Connecting the control inputs to the ORe5 controller is described in its Installation manual, if necessary. Also in the catalog of Vento duct units.*

**Figure 21** – Jumper location



**Table 5** – Recommended cables

Type	Connection	Cable	Voltage
TRN-E	inlet to TRN-E	CYKY – J 3x1,5	230 V ~
	inlet to motor	CYKY – J 3x1,5	230 V ~
	to control	J-Y(St)Y 4x2x0,5	24 V =
	to thermokontacts	H05VWH2 – F 2A×0,75	24 V =
	external starting	H05VWH2 – F 2A×0,75	24 V =
TRN-D	inlet to TRN-D	CYKY – J 4x1,5	3 × 400 V ~
	inlet to motor	CYKY – J 4x1,5	3 × 400 V ~
	to control	J-Y(St)Y 4x2x0,5	24 V =
	to thermokontacts	H05VWH2 – F 2A×0,75	230 V ~
	external starting	H05VWH2 – F 2A×0,75	24 V =

### TRRE, TRRD Transformer Controllers

#### Operating Conditions, poloha

These controllers are intended for indoor applications in dry, dust and chemical free environments. They are designed for normal environmental conditions in accordance with ČSN 33 2000-1 ed.2 (IEC 364-3).

- Degree of protection: IP 20
- Permissible ambient temperature: +5 °C to +40 °C
- Position: always only vertical or horizontal

The controllers can be situated on a wall, air-handling duct or ancillary construction; however, always only in the vertical or horizontal position. The installation must be performed considering the weight of the controller. They can be mounted on A and B combustibility grade materials in accordance with the ČSN EN 13 501-1 standard. The controller casing is provided with ventilation openings which must not be covered. Permanent and easy access to the controller must be ensured.

#### Installation

- The installation and commissioning can be performed only by an authorized company licensed in accordance with valid regulations.
- The controller must be checked carefully before its installation, especially if it was stored for a longer time. In particular, it is necessary to check all parts and cable insulation for damage.
- The controller can be placed on a wall, air-handling duct or ancillary construction only in the vertical or horizontal position. With regard to its weight, the controller is installed in three steps:
  - First, fix the base with 4 screws  $\varnothing$  6 mm.
  - Hang the controller supporting plate, including wiring, on the base, and secure it with a screw.
  - Finally, fix the controller cover.
- The controller must be placed within reach of the operator. The installation must be performed considering the weight of the controller, easy wiring, free cooling openings and its degree of electrical protection.
- As the controller contains sensitive electro-mechanical parts, take care and keep the controller interior clean (avoid dust, sand, plaster, etc).

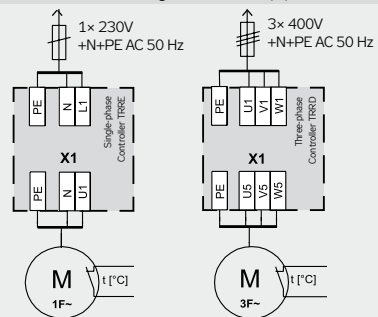
#### Wiring

- The wiring can be performed only by a qualified worker licensed in accordance with national regulations.
- Cables for the power supply, fan motors connection and control are led through plastic grommets and connected to the WAGO terminals in the lower part of the controller casing.
- The TRRE and TRRD controllers are not equipped with an integrated fan motor protection. Therefore, external protection devices must be used (STE, STD relays or control unit).
- The connection must be carried out according to figure 22.
- After connecting the controller and starting the fan, the current must be measured, and it must not exceed the

maximum allowed value in any output stage. The maximum current value is stated on the rating plate as a numerical part of the type code of the controller (e.g. TRN7D means  $I_{max} = 7$  A).

- If the current values are higher, check whether the controller is connected to the appropriate fan; the rated current of the fan should be lower or equal to  $I_{max}$  of the controller.
- If the measured current value still exceeds the maximum permissible value even though the connected fan complies with the above-mentioned criteria, immediately check the duct system regulation. The fan is probably being operated in a so-called forbidden (non-working) area of the fan output characteristics. The proper current value can be reached by the air flow throttling.
- If the current value does not drop even after adjusting the duct system regulation, it is necessary to check the electrical parameters of the entire wiring.
- Each fan should be connected to a separate controller. If this recommendation cannot be fulfilled, max. two fans can be connected to one controller, and enough current margins must be kept, i.e. the minimum rating current of the controller must be 20% higher than the sum of the maximum currents of both fans. Example: The total max. current of two fans RP 60-35/31-6D is  $2 \times 1.86A = 3.72A$ , plus adding 20% margin the controller current is 4.46A. For this value, the first higher controller TRRD 7 will be used.

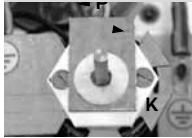
Figure 22 – Terminal diagram of TRRE(D) controllers



## TRRE, TRRD Transformer Controllers

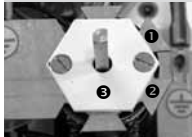
■ The controllers enable mechanical blocking of output stages 0-3. The blocking serves for the minimum air flow setting, i.e. to limit low outputs or to block the "0" stage if the control unit is used. It can be simply carried out by bending the corresponding lamella on the rotary switch coulisse (Figure 23–25).

**Figure 23**



◀ The blocking of a selected output stage can be simply carried out by bending the corresponding lamella on the rotary switch coulisse **K** up, 90° aslant. Thus the arm of the rotary switch **P** is blocked from passing through the position of the given output stage.

**Figure 24**



◀ Stages 0 – 3 can be blocked by bending the corresponding lamellas on the rotary switch coulisse **0 1 2 3**. One or the range of two, three or four successive positions of the rotary switch can be blocked.

**Figure 25**



◀ This figure shows blocking of the output stage **0**. The rotary switch can be turned right or left so all stages except stage **0** are available.

■ The following Table 6 shows the mounting of the individual types of controllers fuses.

**Table 6** – controllers vs. fuse assignment

Controller type	Phase
TRRE 2	1 × T 3,15 A / 250 V
TRRE 4	1 × T 6,3 A / 250 V
TRRE 7	1 × T 8,0 A / 250 V
TRRD 2	3 × T 3,15 A / 500 V
TRRD 4	3 × T 6,3 A / 500V
TRRD 7	3 × T 8,0 A / 500 V
TRRD 9	3 × T 10 A / 500 V

■ Recommended cables for connection or connections between devices are shown in Table 7. The labeling of cable types corresponds to schematic diagrams.

**Table 7** – recommended cables

Type	Connection	Cable	Voltage
TRRE	inlet to TRRE	CYKY – J 3×1,5	230 V ~
	inlet to motor	CYKY – J 3×1,5	230 V ~
TRRD	inlet to TRRD	CYKY – J 4×1,5	3 × 400 V ~
	inlet to motor	CYKY – J 4×1,5	3 × 400 V ~



### EO, EOS, EOSX Electric heaters

#### Installation

- Electric heaters are designed for the environment with the impact of normal class according to ČSN 33 2000-1 ed.2 (IEC 60361-1). Degree of protection is IP 40.
- The heater must be checked carefully before its installation, especially if it was stored for a longer time. It is necessary to check parts for damage, and in particular, whether the heating rods, thermal fuses, insulation of conductors, terminals, etc are in good condition.
- The heaters can operate in any position except the position with the wiring distribution box directed downwards.
- The heater must be installed so that the prescribed air flow direction through the heater will be retained. The prescribed air flow direction is marked on the terminal box by an arrow. The correct air flow direction can also be determined according to the position of the aluminium cooler, which must be situated in cold air flow (in front of the heating rods), (see fig. # 30).
- There is no need for individual suspensions to install the electric heaters. They can be inserted into the duct line, but they must not be exposed to any strain or torsion caused by the connected duct line.
- The heaters must be situated at a safe distance from flammable or easily inflammable materials. The location of the heater must allow free space for heater surface cooling.
- It is necessary to keep easy access to the heater, especially to its wiring distribution box.
- Before installation, paste up to +100 °C heat resistant sealing onto the connecting flange facing the heater.
- Heaters with dimensions up to 80-50 mm are connected to the air-handling duct by 20 mm wide bar flanges and four M8 screws on each flange. Heaters with dimensions up to 90-50 mm are connected to the air-handling duct by 30 mm wide bar flanges and four M10 screws on each flange. To brace the flanges with a side longer than 40 cm, it is advisable to connect them in the middle with another screw clamp which prevents flange bar gapping.
- The lid of the wiring distribution box of heaters up to 30 kW is fixed with four M4 screws, while the lid of the wiring distribution box of 45 kW heaters is fixed with six M4 screws.
- It is necessary to ensure conductive connection of the lid using fan-washers placed on both sides (at least on one connection), or use Cu conductor wiring.
- The electric heater must be provided with automatic control of the output. REMAK units are recommended to supply, control and protect electric heaters.

#### Wiring and Commissioning

- The installation of the heater must be performed in accordance with the project and catalogue (respectively Installation Manual). The installation can be performed only by an authorized company licensed in accordance with generally valid regulations.
- The wiring diagrams of terminals of electric heaters are attached on the following pages.
  - The wiring must be checked before putting the device into operation.
  - Proper functioning of protective and emergency thermo-

stats connection must be checked before commissioning the electric heater. When the circuit of emergency thermostats is disconnected, the control unit must disconnect the power supply to the heater power circuit, and signal failure of the heater due to overheating.

- The EOSX heaters are controlled by voltage of 10-40V/DC from the control unit. When connecting the heater, it is necessary to observe the proper polarity – the heater terminal Q14 (+). If the polarity is reversed, the heater will not heat.
- The control voltage of the EOSX heater is led through a limiting thermostat with a switching point of +45 °C, which is situated on the cooler of the SSR switching relays.
- The heater is provided with two emergency thermostats adjusted to +80 °C. The thermostats are connected to terminals E3 and GE.

#### The Wiring

- The heater supply cables must be dimensioned in accordance with valid technical standards, and maximum current, cable bedding and length must also be taken into account. The cable sections are valid for CYKY cables, type of cable bedding: B, C, E in air at ambient temperature up to +30 °C (ČSN 33 2000-5-523, resp. IEC 364-5-523).
- The cables are led through grommets into the wiring distribution box, which is an integral part of the heater. Inside the wiring distribution box, the cables are interconnected with inner wiring using screw-free clip terminals.
- The heating rods of all heaters are designed for 230V voltage.
- The heaters are provided with two-stage thermal protection with two stand-alone thermostats (for details, refer to the chapter "Thermal Protection").
- Simpler and cheaper heaters in the EO product line, designed for less demanding conditions, are switched by the contactor directly in the control unit.
- EOS and EOSX heaters are switched by electronic non-contact switching relays SSR (Solid State Relay) which are characterized by long service life (indefinite number of closures compared to contactors), low input (15 mW) to switch output rates in kW's, switching at zero voltage, abatable nuisance, without sparking, optically separated input and output (dielectric strength of 4 kV).

#### Thermal Protection

Generally, if the electric heaters are not properly protected and controlled, they can be dangerous. Aside from electrical protection, attention must also be paid to thermal protection. When creating the project layout, we recommend observing the following principles.

- The electric heater output must be automatically controlled.
- The operation of the heater must be blocked if the fan is out of operation for any reason, or the speed of the air flow is limited to below the accepted level.

## EO, EOS, EOSX Electric heaters

- Either the air-handling device is switched off manually or automatically the heater must be switched off first, and then with time delay sufficient for heater cooling, the dampers can be closed and the fan switched off.
  - An air filter must be placed at a sufficient distance in front of the heater. Without using an air filter, there is a danger of the heating rods fouling and being damaged due to insufficient cooling. Sufficient protection can be ensured by a KFD filter with a filter insert.
  - Gradual filter fouling causes a reduction in the air flow rate. Therefore, it is necessary to monitor the filter condition via the differential pressure sensor, and change the filter insert in due time.
  - The speed of the air flow in the electric heater should not fall below 1 – 2 meters per second. If the output of the fan is controlled by the TRN controller, it is possible to block the lower stages of the controller so that the speed of the air flow will not fall below the limit value. As a consequence of breakdown or failing to observe any of the above-mentioned recommendations, an emergency situation could occur due to overheating. Complex and system protection can be ensured by proper connection of the electric heater to the control unit.
- As standard, all heaters are equipped with stand-alone thermal limiters in accordance with the ČSN 33 2000-4-42 (IEC 364-4-42) standards. The thermal limiters (thermostats) permanently prevent the limit temperature in the air-duct and in the wire distribution box from being exceeded.

### Basic (emergency) thermal protection

Thermal protection of all electric heaters is ensured by two emergency thermostats connected into a serial loop. The thermostats are adjusted in production to +80 °C; one reads the temperature among the heating rods while the other reads the temperature inside the wiring distribution box. If the thermo-contact in the loop trips (due to the heater overheating), the power supply of the heater must be disconnected.

### Extended thermal protection

The thermal protection of EOS and EOSX electric heaters is extended by a protective SSR circuit. The temperature of the cooler of the SSR switching relays is read by the third protective thermostat adjusted to a switching point of +45 °C. When this temperature is exceeded, the control signal to SSR is interrupted. After cooling down, the thermostat will automatically switch the control circuit, while the fans work without stopping all the time.

## Operation, Maintenance and Service

The electric heater needs to be regularly checked at least at the beginning of each heating season.

- During operation, the heater must be checked for surface cleanliness, surface temperature, and the connected cables for damage.
- It is necessary to inspect the proper switching functions of protective devices. If the air-handling device is stopped by the emergency system due to heater overheating, it is necessary to find and remove the failure following the respective installation manual.

## Troubleshooting

When you start the air-handling system for the first time, you can face an undesirable situation. The following text includes common sources of problems and their removal:

- **Permanently low output air temperature**
  - Too low temperature was adjusted on the control unit.
  - Too low heater output for the given air flow and  $\Delta T$ .
  - Wrong connection (polarity) of Q14, GC terminals.
  - The limiting thermostat is defective.
  - The electric heater's control circuit has been disconnected
- **Permanently high output air temperature**
  - Required temperature (set in control unit) too high
  - SSR Switching relay fault

- **The output air temperature fluctuates**

- Too high EO, EOS heaters output for the given air flow and  $\Delta T$ .

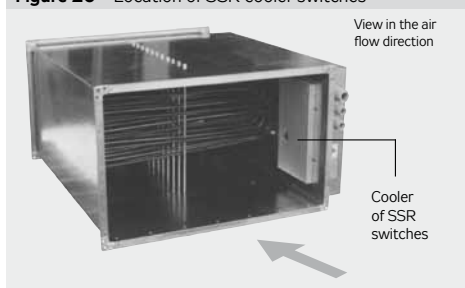
In regulation quality terms, in normal conditions higher temperature fluctuation can be expected with EO and EOS electric heaters controlled by a control unit than with EOSX heaters or EOS heaters with a current valve.

- **Repeated activation of emergency temperature protection**

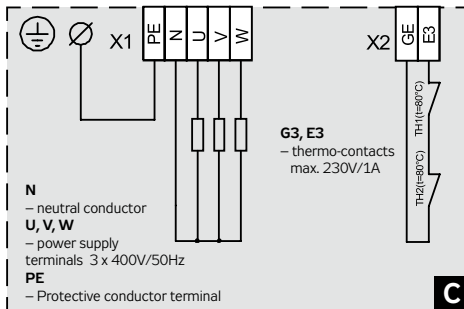
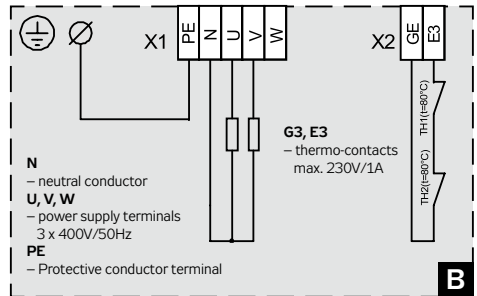
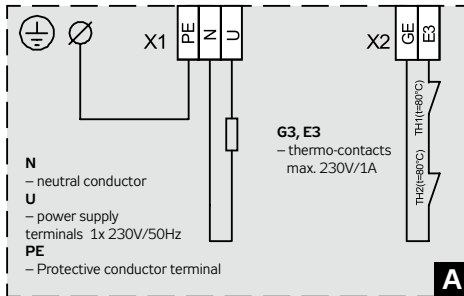
- No air flow due to wrong installation.
- Failure of the emergency thermostat.
- The emergency circuit has been disconnected.
- Defective SSR switching relay.

The above-mentioned failures which cause repeated activation of the temperature protection are serious, and need to be repaired immediately.

Figure 26 – Location of SSR cooler switches

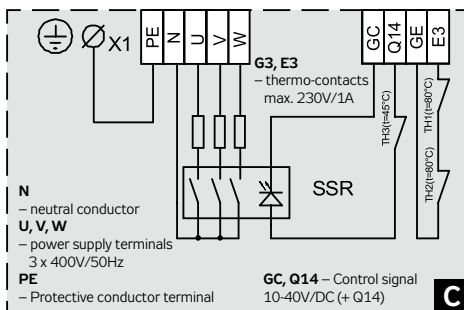
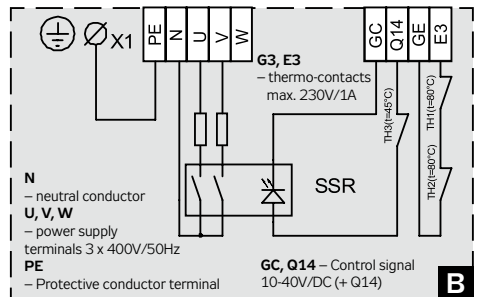
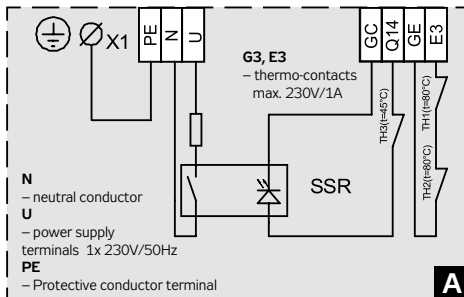


### EO, EOS, EOSX Electric heaters



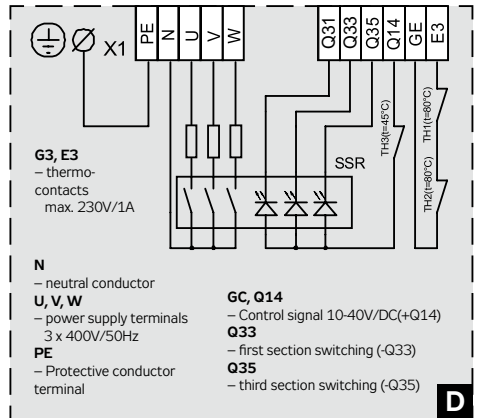
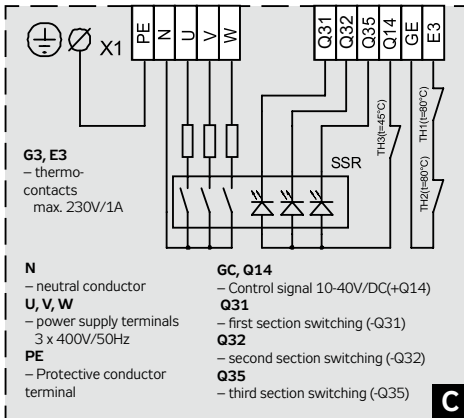
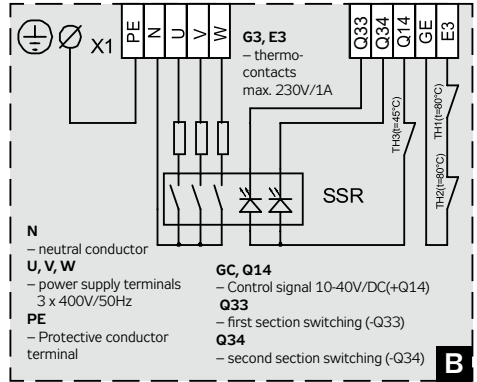
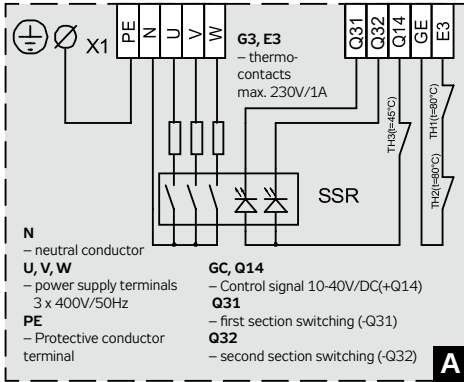
Type/ size	Output (kW) / wiring scheme															
	1,5	2	2,5	3	4	4,5	5	6	7,5	10	12	15	22,5	30	37,5	45
EO 30-15	A				B		C									
EO 40-20		A			B		C				C					
EO 50-25			A				B			C	C		C	C		
EO 50-30							B			C	C		C	C		
EO 60-30										C	C		C	C		
EO 60-35										C	C		C	C		
EO 70-40										C	C		C	C		
EO 80-50											C		C	C	C	C
EO 90-50												C	C	C	C	C
EO 100-50												C	C	C	C	C

### EOS Electric heaters



Type/ size	Output (kW) / wiring scheme															
	1,5	2	2,5	3	4	4,5	5	6	7,5	10	12	15	22,5	30	37,5	45
EOS 30-15	A				B		C									
EOS 40-20		A			B		C				C					
EOS 50-25			A				B			C	C		C	C		
EOS 50-30							B			C	C		C	C		
EOS 60-30										C	C		C	C		
EOS 60-35										C	C		C	C		
EOS 70-40										C	C		C	C		
EOS 80-50											C		C	C	C	C
EOS 90-50												C	C	C	C	C
EOS 100-50												C	C	C	C	C

## EOSX Electric heaters



Type/ size	Output (kW) / wiring scheme					
	12	15	22,5	30	37,5	45
EOSX 40-20	A					
EOSX 50-25		A	B			
EOSX 50-30		A	B			
EOSX 60-30		A	B	C		
EOSX 60-35		A	B	C		
EOSX 70-40		A	B	C	C	D
EOSX 80-50		A	B	C	C	D
EOSX 90-50		A	B	C	C	D
EOSX 100-50		A	B	C	C	D

### VO Water heaters

#### Operating Conditions

The heated air must be without solid, fibrous, sticky, aggressive impurities, free of corrosive chemicals or chemicals aggressive to aluminium, copper and/or zinc.

Maximum allowed operating parameters of heating water:

- Maximum allowed water temperature: **+130 °C**
- Maximum allowed water pressure: **1,6 MPa**

#### Position and Location

When projecting the layout of the heater location, we recommend observing the following principles:

- If water is used as the heating medium then the heater can be situated only in an indoor environment where the temperature is maintained above freezing point (this does not apply for heated air).
  - Outdoor use is allowed only if antifreeze solution is used as the heating medium (mostly ethylene glycol solution). However, the temperature limit of the used actuating mechanism must be taken into account.
  - Water heaters can work in any position in which air-venting of the heater is possible.
  - Free access to the heater must be ensured to enable control and service.
  - An air filter must be installed in front of the heater to avoid its fouling.
  - The counter-current connection of the heater is needed to achieve maximum output.
  - The heater can be situated either in front of or behind the fan. However, if the heater is in front of the fan, the heater output must be controlled so that the air temperature will not exceed the maximum allowed value for the given fan.
  - If the heater is situated behind the fan, we recommend inserting between the fan and the heater a spacer (e.g. 1-1.5 m long straight duct) to steady the air flow.
- Accessories are not included in the heater delivery and must be ordered separately.

#### Air-Venting of the Heater

To ensure proper operation of the heater, it is necessary to install reliable air-venting, the best being automatic. The TACO automatic air-venting valve with outer G1/2" thread is designed to be screwed directly into the heater header pipe. It must be installed on the very top of both header pipes. Thanks to its small dimensions, it is suitable when using the heater just below the ceiling. The heater can be vented either manually or automatically. With regard to the fact that the heater is mostly installed in places difficult to access, at height or on ceilings, automatic air-venting is a necessity. The TACO automatic air-venting valve with outer G1/2" thread (see fig. #27) is designed to be screwed directly into the heater header pipe. It is installed on the very top of both header pipes. Maximum allowed operating parameters of heating water:

- Maximum operating water temperature: **115 °C**<sup>(1)</sup>
- Maximum operating water pressure: **0,85 MPa**
- Minimum operating water pressure: **20 kPa**

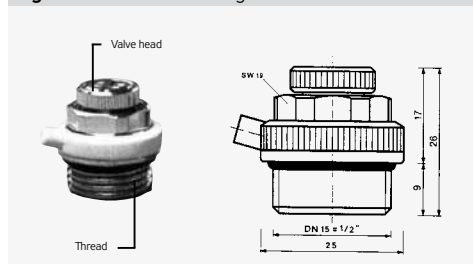
The valve must be installed in the vertical position or aslant with its head upwards, respectively horizontally; by no means downwards!

Minimum water pressure in the system ensures that even if the pressure in the intake part of the mixing set drops, the air-venting valve will not take up air into the outlet heater header pipe.

**Warning! The following antifreeze solutions can be used as heating media:**

- **water and ethylene glycol (Antifrogen N)**
  - **water and 1.2 - ethylene glycol (Antifrogen L)**
- They enable the freezing temperature of the heating media to be dropped depending on the solution concentration. Other antifreeze agents can be used only upon presenting confirmation of the manufacturer confirming their compatibility with swelling materials (ring, inserts).**

Figure 27 – TACO air-venting valve



#### Installation

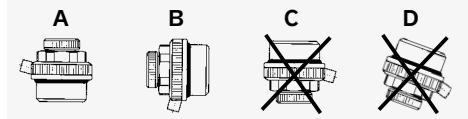
- The heater must be checked carefully before its installation, especially if it was stored for a longer time. It is necessary to check parts for damage, and in particular whether the pipes, heater vanes and header pipes, insulation of conductors of the mixing set pump, etc are in good condition.
- If water is used as the heating medium, then the heater can be situated only in an indoor environment where the temperature is maintained above freezing point (this does not apply for heated air).
- Outdoor use is not recommended. It is allowed only if antifreeze solution is used as the heating medium (mostly ethylene glycol solution). However, the temperature limit of the used actuating mechanism must be taken into account.
- There is no need for individual suspensions to install the water heaters. The heater can be inserted into the duct line, but it must not be exposed to any strain or torsion caused by the connected duct line.
- Before installation, paste self-adhesive sealing onto the connecting flange face. To connect individual parts of the Vento system, use galvanized screws and nuts M8. It is necessary to ensure conductive connection of the flange using fan-washers placed on both sides at least on one flange connection, or use Cu conductor wiring.

(1) In case that the water heater operates with water at 116 °C or higher, it is necessary to ensure the float valve venting

## VO Water heaters

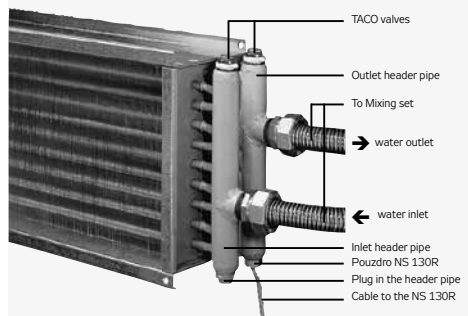
- To brace the flanges with a side longer than 40 cm, it is advisable to connect them in the middle with another screw clamp which prevents flange bar gapping.
- Water heaters can work in any position in which air venting of the heater is possible. The most common heater positions are shown in figure #34. Positions A, B and C show the most suitable places for the TACO air-venting valve mounting (marked with arrows). Position D shows non-permissible installation of the heater which does not allow air venting.
- The TACO air-venting valves must be installed as shown in figure #32, i.e. vertically (upright) with their heads up – view A, or horizontally – view – B, by no means downwards or slanted with their heads down – C, D.
- The TACO air-venting valves must be mounted onto the highest point of the inlet/outlet header pipe (see fig. #30). The openings in the header pipes have G1/2" inner thread and they were closed with plugs in the plant.

**Figure 28 – TACO valve positions**



- The casing of the antifreeze protection NS 130 sensor can be mounted on the bottom side of the header pipe.
- To allow faster air venting while filling the system with water, loosen the knurled screw on the TACO valve by one or two turns. After finishing the filling of the system, tighten the knurled screw firmly, and the valve will then work automatically.
- During the first air venting, a couple of water drops can leak through the air-venting valve. This will not happen again during normal operating conditions.
- When cleaning the TACO valve inside, it is necessary to replace the swelling parts (rings and inserts). The TACO valve is equipped with a back valve so there is no need to drain the heater.
- When connecting the mixing set hoses, thermal sensor

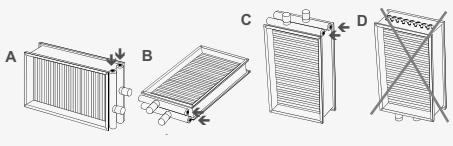
**Figure 29 – TACO valve installation**



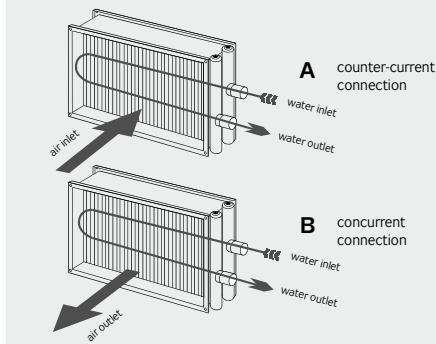
NS 130 casing, or air-venting valve, be careful. Do not use excessive force, otherwise the pipes situated between the header pipes and sidewall of the heater could be damaged!

- An air filter must always be placed in front of the heater to avoid heater fouling.
- The heater can be situated either in front of or behind the fan. However, if the heater is in front of the fan, the heater output must be controlled so that the air temperature will not exceed the maximum allowed value for the given fan.
- If the heater is situated behind the fan, we recommend inserting a 1-1.5 m long straight duct between the fan and the heater to calm the air flow down.
- The counter-current connection of the heater is needed to achieve maximum output (see fig. #35). The concurrent connection provides lower output, but it is more frost resistant.
- The sophisticated design of the heaters enables you to turn on one heater arbitrarily, and you will always be able to arrange counter-current connection and to install the valves and thermal sensor in the right place.
- If the heater is covered by a ceiling, it is necessary to ensure access to the entire heater to enable checking and maintenance, especially of air-venting valves.
- Connection to the water side: G 1 thread (applies to all heaters).

**Figure 30 – Heater positions**



**Figure 31 – Heater connection**



### SUMX Mixing sets

#### Application of Mixing Sets

SUMX mixing sets ensure continuous output control (proportional control using an analogue voltage signal of 0-10 V) and protection of the water heater. Output control is ensured by a change in the water output temperature at constant water discharge. A mixing set connected to the control unit and antifreeze protection system components can effectively protect the heater against freezing followed by its destruction. The below-mentioned information can also be suitably used for integration of the mixing sets into a cooling system equipped with a water heat exchanger.

#### Operating Conditions

The water running through the mixing set must not contain impurities, solids or chemicals aggressive to copper, brass, stainless steel, zinc, plastics, rubber or cast iron.

The heating system inlet branch must always be equipped with a **sludge** and **cleaning filter**. The mixing set must not be operated without this filter.

The permissible ambient temperature is 0 °C to 70 °C for the media temperature of 105 °C (for the media temperature of 110 °C the max. ambient temperature is 35 °C / 55 °C for SUMX 1–16). Minimum media temperature is +2 °C. Maximum allowed operating parameters of heating water:

- Maximum allowed water temperature: **+110 °C (+95 °C pro SUMX 10 až SUMX 16)**
- Max water pressure for SUMX 1–25: **1 MPa**
- Maximum water pressure for SUMX 28-90: **0,6 MPa**

For installations using hot water up to 130 °C, it is possible to use the so-called inverted (reverse) mixing set configuration with a pump situated in the return water branch to ensure the required water temperature of 110 °C in the heater outlet. The designation of the inverted mixing set is **SUMX..i**.

Sealing of a corresponding quality must be used for the installation. It is advisable to consult the manufacturer.

- If water is used as the heating medium, the mixing set can only be situated in an indoor environment where the temperature never falls below freezing point. Outdoor installation is acceptable only if glycol antifreeze solution is used as the heating medium. Salt brine solutions are not recommended, see the chapter "Water Heaters".
- In applications in which it is necessary to avoid primary circuit water cooling or in applications in which it is necessary to avoid interference from the primary and secondary circuit pumps (undesirable heating water flow direction through the heater), it is possible to equip the primary circuit with a bypass (respectively with a thermo-hydraulic separator). The bypass should be situated as close as possible to the mixing set connection point. The heating water bypassing increases the return water temperature therefore, the bypass (thermo-hydraulic separator) must not be used in association with modern condensing boilers. The same applies if the heating water supplier does not allow the cooled water to be returned to the system.

⚠s the mixing set pump overcomes only the secondary circuit (the heater circuit) pressure losses, the primary circuit pump must be designed to cover all pressure losses up to

the mixing set at the nominal water discharge which has been determined by the water heater design.

The primary circuit pump must not affect the mixing set pump, i.e. the mixing set must not be loaded by the pressure from the primary circuit. It is not advisable to include other consumers in the heater's circuit. Further, it is necessary to equip the primary circuit inlet and outlet branch with ball closing valves and the inlet branch with a sludge and cleaning filter (which should also be separated by a closing valve).

- The mixing set must not be operated without a sludge and cleaning filter.
- **Components of the primary circuit are not the subject of the delivery from REMAK a.s.**

#### Position and Location

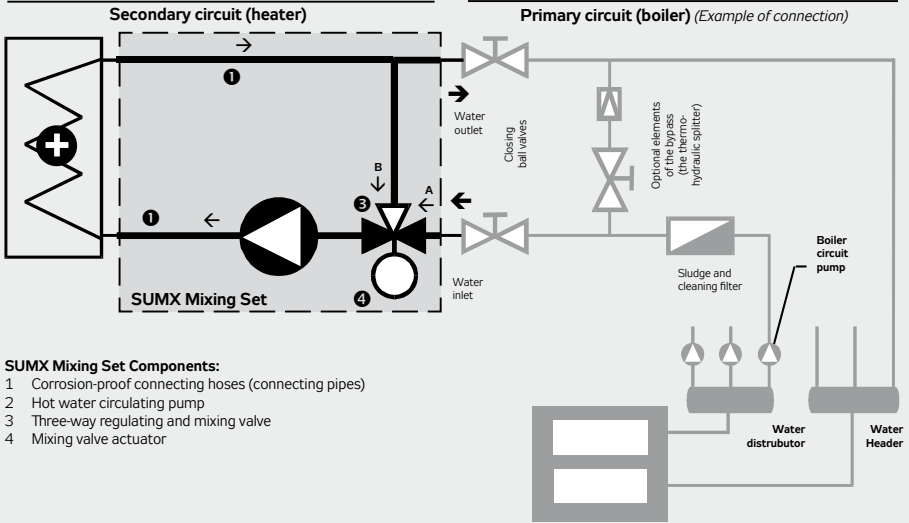
When projecting the layout of the mixing set location, we recommend observing the following principles:

- The mixing set must be mounted so that the shaft of the circular pump motor will always be in the horizontal position!
- The mixing set must be situated so that air-venting will be possible.
- If the mixing set is covered by a ceiling, it is necessary to ensure access to the entire set to enable maintenance.
- The mixing set is connected to the heater via corrosion-proof hoses while the flange assembly should be mounted using standard heat-engineering techniques as close as possible to the heater. It is advisable to minimize the length of the hoses so that the control response will not be unnecessarily delayed.
- The mixing set is mounted using an integrated holder, respectively, tube clamps can be used, if necessary. The weight of the mixing set must never be transferred onto the heat exchanger. The flange-connected mixing sets are delivered disassembled. The connecting hoses are not included in the delivery.

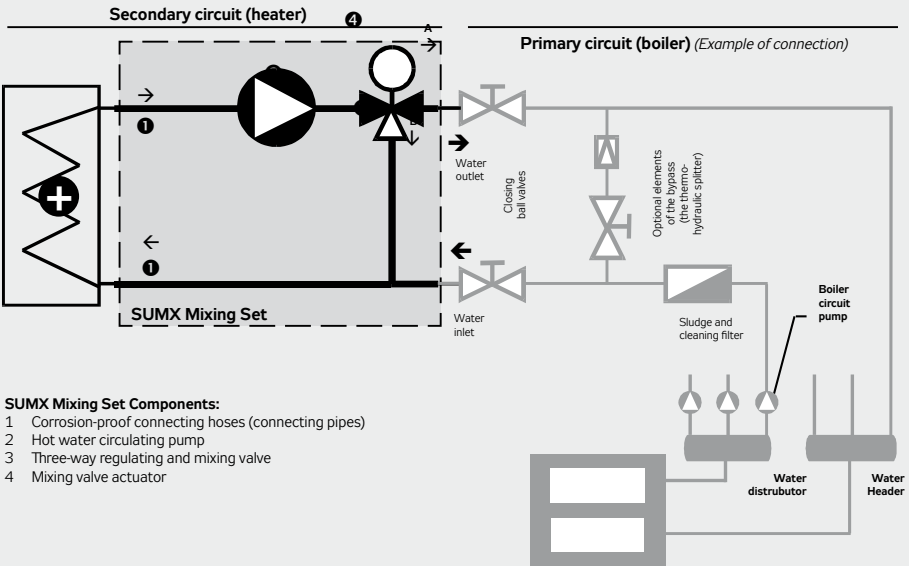
## SUMX Mixing sets

Figure 32 – Connecting scheme of the heater and mixing set in a heating system

### a) Standard connection (mixing)



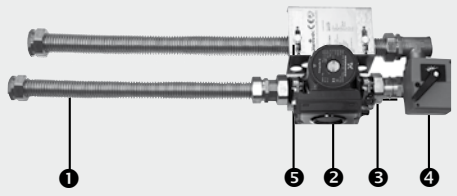
### b) Inverted connection (separation)



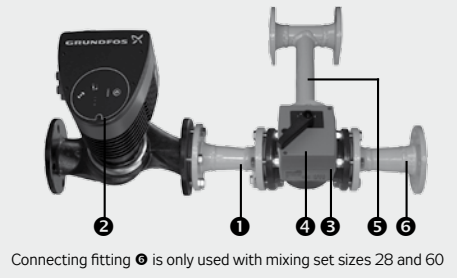


### SUMX Mixing sets

**Figure 33** – Basic layout of mixing sets



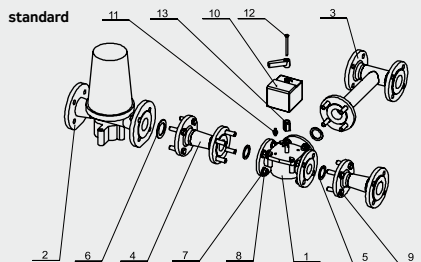
**Figure 34** – Basic layout of mixing sets



### Installation

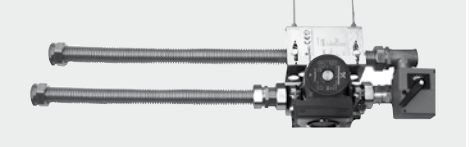
- SUMX 1-25 mixing sets are connected directly to the heater via corrosion-proof hoses. If needed, the hoses can be cut to the desired length before installation.
- The mixing set must not be exposed to any strain or torsion caused by the connected pipe line.
- The mixing sets can be mounted on separate suspensions using an integrated holder, or using clamps (figure #40).
- If the mixing set is covered by a ceiling, it is necessary to ensure access to the entire mixing set to enable electric cable connections, checking and maintenance.

**Figure 36** – Exploded view of the mixing set

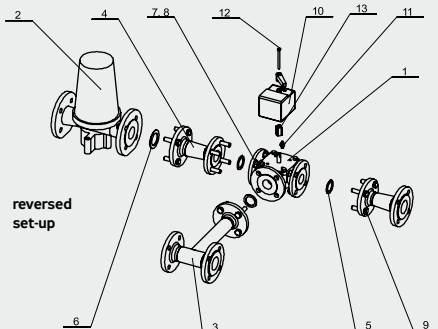


- (1) Valve, (2) Pump, (3) T-piece, (4) making-up piece, (5) Sealing, (6) Sealing, (7) Washer, (8) Nut, (9) Screw, (10) Actuator, (11) Pin, (12) Fixing screw, (13) Adapter

**Figure 35** – Installation using suspension rods



- SUMX 28 - 90 flange-connected mixing sets can be connected to heat exchangers using standard heating engineering procedures; among others, it is necessary to ensure adaptation to threaded connections of the heat exchangers - refer to the heat exchanger technical details. It is advisable to use clamps to connect the flange-connected mixing sets to the suspensions or supporting brackets.
- The mixing set must be installed in such a way that the air in the piping will be able to run to the air-venting valves of the heater or boiler piping. Especially the connecting corrosion-proof hoses must be shaped after installation so as not to create an air trap.
- The mixing set must be positioned so that the shaft of the circular pump will always be in the horizontal position!
- The circular pump must be vented after the system has been filled with water in accordance with the manufacturer's instructions.
- When connecting the mixing set, it is necessary to check the correctness of the adjustment of the three-way valve and actuator. One way of the three-way valve, to which the bevelled spot on the valve shaft points, is always closed (figure # 41 shows the three-way valve's function).
- Flanged mixing sets are delivered disassembled, assembly must be performed in accordance with Figure 36.
- When the actuator rotates incorrectly, it is only needed to adjust rotational direction switch S1 to the second position. The switch is accessible after removing the actuator cover, see Fig. 47.



## SUMX Mixing sets

### Pump Curve Settings

■ The speed of the circular pump is indicated in the project after the type designation of the mixing set. For example, the mixing set SUM 6,3 (3) is equipped with the UPM3 25-70 pump which is set to speed 3, the number in parentheses (3). The speed of the pump can be adjusted by the button on the pump during installation (fig. 37).

#### Curve Settings for UPM3 FLEX AS 25-70

- Press the button for  $t > 2$  s, the pump enters the settings mode.
- Each pressing of the button changes the settings (fig. 38).
- To lock/unlock the pump settings, press and hold the button for  $t > 10$  s

Figure 37 – Pump Speed Settings (curves)



Figure 38 – Settings Menu

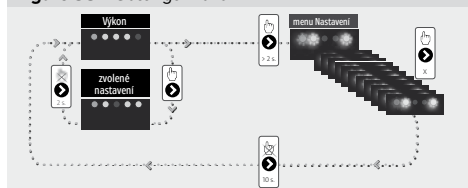
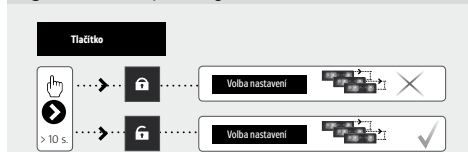


Figure 39 – Curve Settings



Figure 40 – Pump Settings Lock

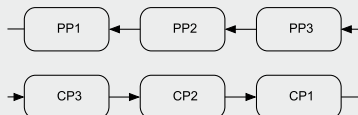


### UPML 25-95 AUTO Pump Settings

The user interface allows the selection of six control curves in two control modes:

- Three proportional curves (PP)
- Three constant pressure/output curves (CP)

Figure 41 – Pump Operating Modes



- Press and hold the button for  $t > 2$  s, the pump enters the settings mode. LED will start to flash.
- Each pressing of the button changes the settings:

#### ● The Mode is flashing:

- Quickly: Proportional pressure
- Slowly: Constant pressure/Output

#### ● Not pressing the button for ten seconds:

- UPML 25-95 AUTO pump settings will be changed.
- The pump will enter the operating mode.

#### ● LED 1 or 2 or 3 is permanently on.

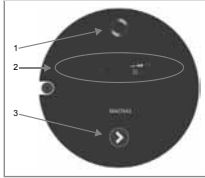
- The pump runs according to the selected curve and mode.

Figure 42 – Pump Settings Display

III II I	Flashing quickly	PP1
III II I	Flashing quickly	PP2
III II I	Flashing quickly	PP3
III II I	Flashing slowly	CP1
III II I	Flashing slowly	CP2
III II I	Flashing slowly	CP3

### SUMX Mixing sets

Figure 43



#### MAGNA1 Pump Curve Settings

- Operation and Failure Signalling
- Indication of the set pump operating mode
- The button is used to set the pump operating mode (fig. 43).

- Number of the button (3) pressings corresponds to the set pump operating mode, see fig. 44

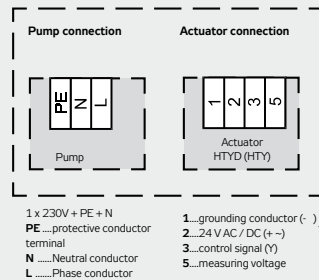
Figure 44 – Pump Operating Mode Settings

Button presses	Light signalling	Mode/Description/Designation
0		Advanced/proportional pressure / <b>PP2</b>
1		The highest/Proportional pressure / <b>PP3</b>
2		The highest/Constant pressure / <b>CP1</b>
3		Advanced/Constant pressure / <b>CP2</b>
4		The highest/Constant pressure / <b>CP3</b>
5		Constant curve/Constant speed <b>III</b>
6		Constant curve/Constant speed <b>II</b>
7		Constant curve/Constant speed <b>I</b>
8		The lowest/Proportional pressure / <b>PP1</b>

#### Wiring

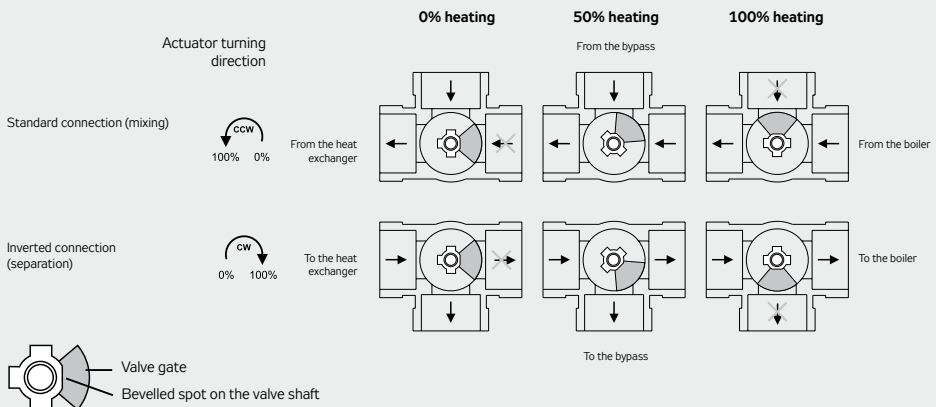
- The wiring can be performed only by a qualified worker licensed in accordance with national regulations.
- The pump must be connected via the terminal box in accordance with the manual. The actuator is equipped with a cable which must be connected in a wiring box (not included in the delivery).
- The mixing set pump and actuator are supplied and controlled by the control unit.
- For the mixing set wiring diagram, refer to figure # 45.

Figure 45 – Mixing set wiring diagram



- The principle diagram of the mixing set connection to the control unit is shown in figure # 46.
- After connecting the mixing set, it is necessary to check the correctness of the actuator function depending on the control signal (heating " no heating).
- After turning the pump on, it is necessary to measure the feed current, which must not exceed the allowed current  $I_{max}$  stated on the pump rating plate.

Figure 48 – Three-way valve function



## SUMX Mixing sets

Figure 46 – Mixing set connection

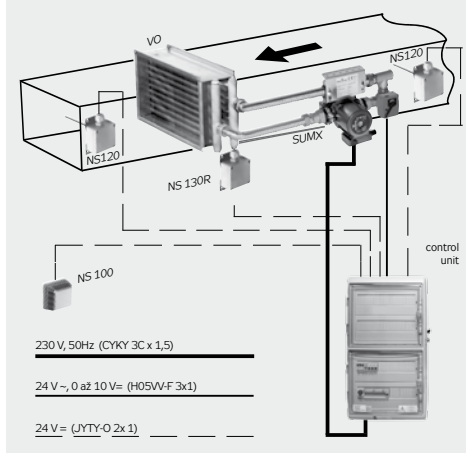
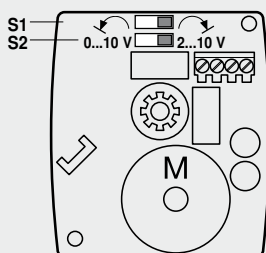


Figure 47 – Switching the actuator turning direction



## Operation, Maintenance and Service

- The mixing set requires regular maintenance at least at the beginning and end of the heating season.
- During operation, it is necessary to check the system for proper air venting and water leakage. It is necessary to supervise proper operation of the pump and actuator, and keep the filters in front of the mixing set clean. If the air-handling system is stopped due to the action of the antifreeze protection, the reason must be found and removed, refer to the chapter "Troubleshooting".

All important system protection functions, including antifreeze protection of the mixing sets and heaters, must be permanently controlled by the control unit.

**Attention! During the winter season, the control unit must not be disconnected from the power supply for too long! Power supply failure during air-handling system operation is especially dangerous!**

## Troubleshooting

When activating the air-handling system, you can face some undesirable situations. The following text includes the most common problems and their removal:

- **Permanently low output air temperature**
  - Low hot water flow or pressure in the boiler piping
  - Low water temperature in the boiler piping
  - Low air temperature adjusted on the control unit
  - Low speed of the pump in the SUMX mixing set
  - Clogged screen in the SUMX mixing set
  - Wrong adjustment of the three-way valve and actuator
  - Aerated pump (resp. whole system)
  - Wrong design of the VO and SUMX assembly
- **Permanently high output air temperature**
  - Too high water flow and pressure in the boiler piping
  - Too high air temperature adjusted on the control unit
  - Wrong adjustment of the three-way valve and actuator
  - Wrong design of the VO and SUMX assembly
- **The output air temperature fluctuates**
  - Too high water flow and pressure in the boiler
  - Wrong adjustment of the three-way valve and actuator
  - Wrong design of the VO and SUMX assembly
- **Repeated activation of an antifreeze protection**
  - Low hot water flow or pressure in the boiler piping
  - Low water temperature in the boiler piping
  - Low air temperature adjusted on the control unit
  - Low speed of the pump in the SUMX mixing set
  - Clogged screen of the SUMX mixing set
  - Wrong adjustment of the three-way valve and actuator
  - Aerated pump (resp. whole system)
  - Wrong design of the VO and SUMX assembly

Repeated activation of the antifreeze protection can also be caused by too high temperature amplitudes. The reasons are listed in the paragraph above.

If the output water temperature is permanently above +30°C, the problem can be caused by failure of the control system or sensor.

SUMX Mixing sets

### Operating Conditions

The cooled air must be without solid, fibrous, sticky, aggressive impurities, and free of corrosive chemicals or chemicals aggressive to aluminium, copper and zinc.

Maximum allowed operating parameters of cooling water:

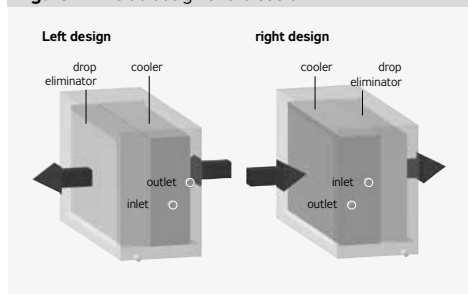
- Maximum allowed water pressure: 1,5 MPa

### Position and Location

When projecting the layout of the cooler location in the air-handling system, we recommend observing the following principles:

- If water is used as the cooling medium, then the cooler can be situated only in an indoor environment where the temperature is maintained above freezing point (the main condition is to maintain the temperature of transported air).
- Outdoor use is allowed only if antifreeze solution is used as the cooling medium (mostly ethylene glycol solution). However, the temperature limit of the used actuating mechanism must be taken into account.
- Water coolers can work only in the horizontal position in which condensate draining and air venting of the cooler is possible.
- Access to the cooler must be ensured to enable checking and service.
- An air filter must be installed in front of the cooler to avoid its fouling (providing it is not already installed in front of the heater).
- The counter-current connection of the cooler (water inlet nearer the air outlet side of the cooler, see Figure 42) is needed to achieve maximum output.
- The cooler can be situated either in front of or behind the fan.
- If the cooler is situated behind the fan, we recommend inserting between the fan and the cooler a spacer (e.g. 1–1.5 m long straight duct) to steady the air flow.

Figure 42 – side design of the cooler

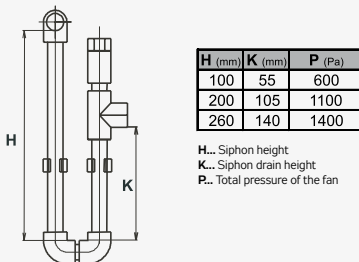


### Condensate Draining

The cooler is equipped with a pan to collect condensate.

The pan is finished with an outlet to connect the condensate draining kit. Condensate draining kits are delivered as optional accessories. The siphon height depends on the total pressure of the fan, and ensures its proper functioning. The siphon must be designed depending on the fan pressure (see fig #43).

Figure 43 – Condensate Draining



### Installation, Service and Maintenance

- The cooler must be checked carefully before its installation, especially if it was stored for a longer time. It is necessary to check parts for damage, and in particular whether the pipes, cooler vanes and header pipes, insulation of conductors of the mixing set pump and actuator are in good condition.
- If water is used as the cooling medium, then the cooler can be situated only in an indoor environment where the temperature is maintained above freezing point.
- Outdoor use is not recommended. It is allowed only if antifreeze solution is used as the cooling medium (mostly ethylene glycol solution concentrated depending on the temperature). However, the temperature limit of the used actuating mechanism of the mixing set must be taken into account.
- There is no need for individual suspensions to install the water coolers. The cooler can be inserted into the duct line, it must not be exposed to any strain or torsion caused by the connected duct line.
- Before installation, paste self-adhesive sealing onto the connecting flange face. To connect individual parts of the Vento system, use galvanized screws and nuts M8. It is necessary to ensure conductive connection of the flange using fan-washers placed on both sides at least on one flange connection, or use Cu conductor wiring.
- Water coolers can work only in the horizontal position, in which condensate draining and air venting of the cooler are possible.
- To allow faster air venting while filling the system with water, remove the upper cover of the cooler, and loosen the knurled screw on the TACO valve by one or two turns. After finishing the filling of the system, tighten the knurled screw firmly, and the valve will then work automatically.

### CHV Water coolers

- During the first air venting, a couple of water drops can leak through the air-venting valve. This will not happen again during normal operating conditions.
- When cleaning the TACO valve inside, it is necessary to replace the swelling parts (rings and inserts). The TACO valve is equipped with a back valve so there is no need to drain water from the cooler.
- Warning: The following antifreeze solutions can be used as heating media:
  - water and ethylene glycol (Antifrogen N)
  - water and 1.2 - ethylene glycol (Antifrogen L)
- When connecting the mixing set hoses or air-venting valve, be careful. Do not use excessive force, otherwise the pipes situated between the header pipes and the sidewall of the cooler could be damaged.
- Connection to the water side: all the cooler outer thread G 1".
- When placed under the soffit a control and service access to the entire heater must maintain. Notably the bleed valves require inspection and maintenance.
- Before operating the unit or after being out of operation longer, it is necessary to fill the siphon via the plastic plug with water. The unit can also be equipped with a siphon with a disconnecting trap and a ball valve (only pressured sections). This type of siphon need not be filled with water before putting it into operation.

### CHF direct coolers

#### Operating Conditions

The cooled air must be without solid, fibrous, sticky, aggressive impurities, and free of corrosive chemicals or chemicals aggressive to aluminium, copper and zinc. The cooler evaporator is filled with protective gas which is discharged after the evaporator is connected to the cooling circuit. The following operating coolants can be used: R134a, R407c, R410a atd. – na základě projektu s výpočtem chladicího kruhu).

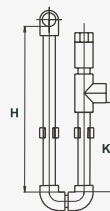
#### Position and Location

- When projecting the layout of the cooler location in the air-handling system, we recommend observing the following:
- Direct coolers can work only in a position in which condensate draining is possible.
  - Access to the cooler must be ensured to enable checking and service.
  - An air filter must be installed in front of the cooler to avoid its fouling (providing it is not already installed in front of the heater).
  - The counter-current connection of the direct cooler is needed to achieve maximum output.
  - The cooler can be situated either in front of or behind the fan.
  - If the cooler is situated behind the fan, we recommend inserting between the fan and the evaporator a spacer (e.g. 1–1.5 m long straight duct) to steady the air flow.

#### Condensate Draining

The cooler is equipped with condensate collection tub, finished with an outlet for condensate draining connection kit. Draining condensate kits are only available as separately ordered accessories. The siphon height depends on the total pressure of the fan and ensures its proper function. The siphon must be designed according to the fan pressure (Figure 44).

Figure 44



H (mm)	K (mm)	P (Pa)
100	55	600
200	105	1100
260	140	1400

H... Siphon height  
 K... Siphon drain height  
 P... Total pressure of the fan

#### Installation, Service and Maintenance

- Installation, servicing and maintenance can be performed only by a specialized company licensed in accordance with valid regulations.
- here is no need for individual suspensions to install the CHF direct coolers. The cooler can be inserted into the duct line, but it must not be exposed to any strain or torsion caused by the connected duct line.
  - Before installation, paste self-adhesive sealing onto the connecting flange face. To connect individual parts of the Vento system, use galvanized screws and nuts M8. It is necessary to ensure conductive connection of the flange using fan-washers placed on both sides at least on one flange connection, or use Cu conductor wiring.

### HRV Plate heat exchangers

#### Operating Conditions and Position

Inlet and outlet air must be without solid, fibrous, sticky, and aggressive impurities.

The heat exchanger is designed to be installed into the air-handling system, into a parallel, perpendicular or 45° aslant air inlet/outlet duct line, or their various combinations. The disposition variability of the heat exchanger is provided by connecting elbows OBL.../45. The number of these elbows must be specified in the project, depending on the intended disposition. The SKX mixing section can be connected directly to the heat exchanger via elbows for the parallel air outlet. The HRV heat exchanger even without elbows has the standard connecting dimensions of the Vento System. The HRV heat exchanger can be operated either in the horizontal or vertical position. However, condensate draining from the outlet air duct behind the heat exchanger must be ensured. When planning the air-handling system, it is necessary to consider requirements for the servicing space to enable the replacement of heat-exchange inserts.

#### Installation, Installation

- Installation of HRV heat exchangers is similar to other Vento components. The flange dimensions are compatible with Vento components. The casing of the HRV heat exchanger is provided with holes in its corners. These holes can be used to suspend the heat exchanger on threaded rods M8.
- Before installation, paste self-adhesive sealing onto the connecting flange face.
- It is necessary to ensure conductive connection of the flange using fan-washers placed on both sides at least on one flange connection.
- The condensate is created on individual vanes (heat exchange surfaces); therefore, the heat-exchange insert is always situated inside the heat exchanger casing with its side marked with the VRCH (TOP) label up. This along with the shape of the vane surfaces minimizes the possibility of accumulation of condensate on individual layers, and thus continuous draining of condensate drops from the vane surfaces is ensured. As the inlet and outlet air line branches intersect within the heat exchanger, the actual air flow cross-section is approx. half of its entire cross-section, and the air flow speed is doubled. Due to the actual air flow speed, condensate drops can be carried from the vanes down the air duct. In installations where this can happen, it is necessary to slope the duct behind the heat exchanger down, solder the joints, and provide the lowest duct point with a condensate draining outlet. The distance the condensate drops fall extends with increasing air flow speed. Depending on the air flow speed, this distance can be 1-3 m behind the heat exchanger.
- The condensate draining PVC outlet is delivered with the heat exchanger. It can be connected to the lowest point of the heat exchanger lid, which serves as a pan, to drain the condensate from the heat exchanger (if the heat exchanger is suspended under the ceiling, the lid downwards), see fig. #45.
- If the HRV heat exchanger is installed on the floor with its lid up, the condensate draining outlet is installed only in

the following air duct. Therefore, all condensate runs out from the heat exchanger into the duct.

#### Recommendation:

- Air filters must be installed in front of the cold and hot air inlets to avoid fouling of the heat-exchange surfaces, successive reduction of the heat exchange effectiveness, and increasing pressure losses.
- To brace the flanges with a side longer than 40 cm, it is advisable to connect them in the middle with another screw clamp which prevents flange bar gapping.

#### Operation and Maintenance

HRV heat exchangers, when used in accordance with the chapter „Operating Conditions and Position“, do not require special maintenance. Checking is usually performed when changing the winter assembly for the summer one, and vice-versa. To avoid condensation problems, it is necessary to keep the condensate drainage free. The replacement of the block shaped heat-exchange insert (resp. summer assembly) can be performed after removing the four wing screws from the bottom lid of the heat exchanger. The block is secured inside the heat exchanger by movable locking pieces. After loosening the securing screws, the locking pieces can be shifted aside (see fig. #46) and the heat exchange insert can be removed from the casing. If the heat exchanger is suspended, it will be necessary to push (lift) the heat-exchange insert to release the locking pieces. The fouling can be carefully removed from the vanes of the heat-exchange insert by washing it out with detergent solution.

Figure 45 – Condensate outlet

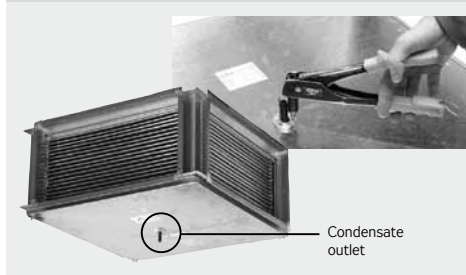
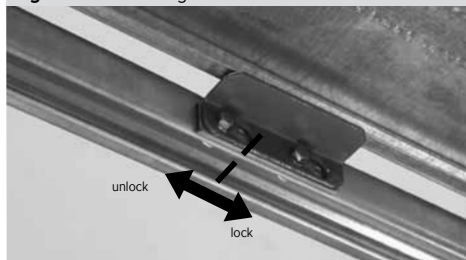


Figure 46 – Securing screws





### HRZ Plate heat exchangers

#### Operating Conditions and Position

Inlet and outlet air must not contain solid, fibrous, sticky, aggressive or explosive contaminants. Heat exchangers are designed to be installed into the air-handling system, into a parallel, perpendicular or diagonal (45°aslant) air inlet/outlet duct line, or their various combinations. The disposition variability of the heat exchanger is provided by connecting elbows. The number of these elbows must be specified depending on the intended disposition.

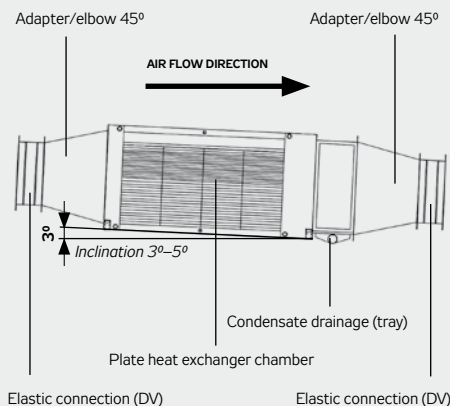
#### Warning:

- RHRZ heat exchangers without elbows or reducing adapters (the reducing adapters are specified but not included in the Remak delivery) do not have the standard connecting dimensions of the Vento system.
- These heat exchangers are designed only for indoor installation in the horizontal (overhead) or vertical (wall) position. If installed in the vertical position, condensate drainage from the outlet air duct behind the heat exchanger must be ensured.
- When designing the air-handling system, it is necessary to ensure access space for installation of the heat exchanger and servicing of the M&C elements.
- The chamber must always be suspended in the balanced position.

To ensure ideal condensate drainage, it is recommended to suspend the chamber with a positive inclination (towards the condensate drainage tray), 3° to 5° aslant depending on the condensate volume and pressure conditions. These effects cannot be defined in advance. Therefore, the installation should be performed so that additional inclination adjustment will be possible. The adjustment of the chamber inclination in relation to the building structure and air handling assembly can be enabled by using an elastic connection on fans along with elastic connections on other branches (not included in the Remak delivery).

**Positioning with a negative inclination in relation to the condensate drainage is PROHIBITED!**

**Figure 54 – Chamber suspension with a positive inclination**



#### Mounting and Installation

Installation of the heat exchanger can be performed in a way similar to the installation of other Vento system components. The specified dimensions of the reduction element inlet and outlet flanges (elbows and reduction adapters) are compatible with other elements of the duct line.

#### HRZ Chamber Suspension

##### Horizontal position (overhead installation)

The heat exchanger chamber can be suspended either using Z-hangers with silent-blocks (included in the Remak delivery) and M8 threaded rods (not included in the Remak delivery) or using other options, i.e., using suspension bars or brackets (not included in the Remak delivery).

##### Vertical position (wall installation)

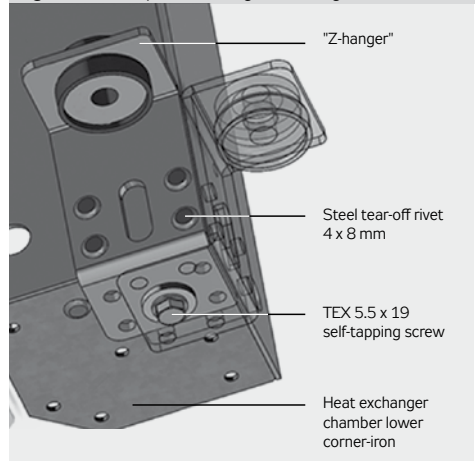
It is recommended to support and secure the heat exchanger chamber in the location of the edge support profiles. It is advisable to use suitable rubber pads between the chamber and supports (not included in the Remak delivery).

#### Z-Hanger Installation

The Z-hanger with a silent-block is designed only for horizontal overhead installation of the unit using the M8 threaded rods, and is always situated in the lower corners (corner-iron) of the heat exchanger chamber. When installing the Z-hanger, it is possible to select the side of the suspension silent-block location, e.g., due to the damper actuator linkage (if the Z-hanger collides with the actuator).

The Z-hanger is secured to the chamber corner-iron by the "TEX" 5.5 x 19 self-tapping screw with the M8 washer and four steel tear-off rivets 4 x 8 mm – if the location of the Z-hanger is changed, it is necessary to drill new holes for the rivets according to the holes in the Z-hanger using a drill bit of 4 mm diameter.

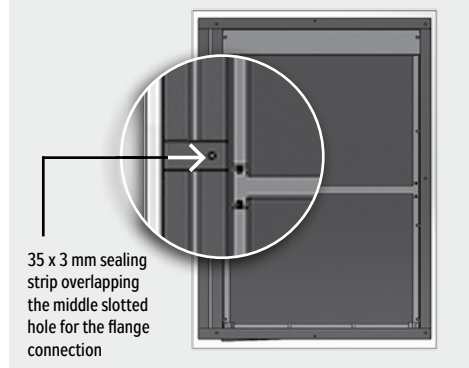
**Figure 55 – Suspension using the Z-hanger**



## HRZ Plate heat exchangers

**Note:** To maintain the joint tightness and strength when connecting the 45° elbows, reduction adapters or other elements of the air-handling assembly to the flange of the condensate drainage tray, we recommend applying a self-adhesive 35 x 3 mm sealing strip (included in the Remak delivery).

Figure 56 – sealing strip application



### Installation of 45° Elbows and Reduction Adapters

Before installation, always apply self-adhesive sealing onto the connecting flange faces of the 45° elbows and reduction adapters. The connection of the elbows and reduction adapters to the heat exchanger chamber is carried out using the flange with pressed nuts situated in the connecting chamber wall corners. To brace flanges with a side longer than 40 cm, it is advisable to also connect them in the middle (to prevent flange bar gapping). This centre connection to the heat exchanger chamber is carried out using self-tapping screws and to the duct or reduction adapter using screw coupling clamps. It is necessary to ensure conductive connection of the flange using fan-washers placed on both sides, on at least one flange connection.

### Mixing Damper Installation

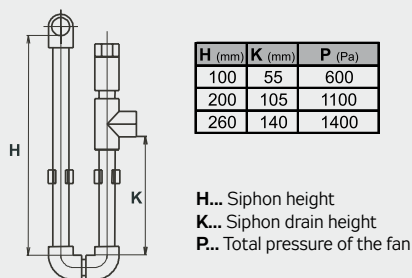
Before installation, always apply self-adhesive sealing onto the connecting flange faces. The connection of the mixing damper to the heat exchanger chamber is carried out through with the pre-drilled holes in the flange to the pressed nuts on the connecting wall of the heat exchanger. It is necessary to ensure conductive connection of the damper flange using fan-washers, on at least one flange connection. If the damper is equipped with a linkage and actuator situated on the side, it is possible to change the right-hand or left-hand linkage location by turning the entire damper according to operating needs or space requirements.

**Note:** If retrofitting the mixing damper, the by-pass cover panel must be disassembled and removed to open the air inlet on the mixing damper side – the cover panel can be unscrewed from outside, i.e., from the side where the mixing damper is to be installed.

### Condensate Drainage installation

It is recommended to place the siphon right behind the tray neck. The correctly selected siphon height depends on the total pressure of the fan, and ensures its proper functioning. The siphon height dimensions must be designed depending on the fan pressure.

Figure 57 – Condensate Draining

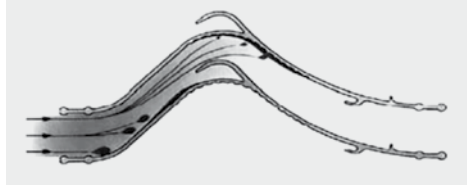


The condensate drainage tray is attached to the structure using sealing and screws which enable removal of the tray and its side arrangement – the left-hand or right-hand neck location.

### Drop Eliminator Installation

The prepared attachments are situated in the condensate drainage tray's duct piece area, enabling the installation/insertion (also retrofitting) of the eliminator. The eliminator can be inserted into the condensate drainage tray's duct piece area through the removable (screwed) side covers of the duct piece, or through the removable (screwed) tray in the lower part of the duct piece. Removal of the eliminator, e.g., for cleaning, can be performed in the same way.

Figure 58 – The correct orientation of the eliminator's fin



**Note:** Please ensure the correct orientation of the eliminator's fins.

### HRZ Plate heat exchangers

#### Installation of the M&C Elements

If necessary, the M&C elements can be installed/attached to the external side of the corner profiles of the chamber casing (here, the attachment holes can be drilled into the chamber casing).

Recommended locations of the M&C elements:

- NS 120 – standard installation on the ductwork, 45° elbow or reduction adapter behind the heat exchanger in accordance with the Sensor Installation Instructions.
- CAP (capillary tube) – installation on the chamber casing. The capillary tube must be evenly distributed in the area behind the heat exchanger.
- P33N – installation on the ductwork, 45° elbow or reduction adapter of the outlet branch in front of or behind the heat exchanger.

**Warning: Never drill or install the M&C elements to the chamber bottom or chamber cover – there is a risk of damage to the heat exchanger or leakage from the casing.**

#### Operation and Maintenance

When used in accordance with the project designed in AeroCAD software and instructions in the "Operating Conditions and Position" chapter, the HRZ heat exchangers require only minimum maintenance related mainly to the cleanliness of the condenser, free passage through the condensate drainage, functionality (rotation) of the dampers and functionality of the M&C elements.

#### Inspections

(minimum recommended interval for inspections and cleaning - 2x per year)

- Check the intactness and internal cleanliness of the heat exchanger and eliminator.
- Check the functionality of the dampers, linkage and actuators.
- Check the functionality of the installed M&C elements.
- Check free passage through the entire condensate drainage.
- Check the state of the unit's suspension

#### Access to Individual Components of the HRZ Heat Exchanger

- The dampers (by-pass and mixing) with actuators are installed from the outer side of the chamber – free access
- The installed heat exchanger – access through the elbows, reduction adapter (removable) and from above through the removable (screwed) cover of the heat exchanger chamber
- By-pass area – access from above through the removable (screwed) cover of the heat exchanger chamber
- The ductwork piece and tray with an eliminator – access through the removable (screwed) side covers and removable condensate drainage tray

#### Warning:

- The VCS control system includes the function of heat exchanger drying which, using fan run-out, helps remove the remaining condensate when the equipment is switched off. If a quick service action is needed, the equipment must be switched off via the main switch to eliminate fan run-out.
- The heat exchanger is made of thin aluminium profiles. Any unqualified handling can cause permanent and irreparable damage.
- The bypass duct must be regulated so that the air pressure loss in the duct bypass will be approximately the same as the air pressure loss in the heat exchanger. Otherwise, the parameters of the air-handling system could be changed, respectively the working point of the supply fan could be shifted into the non-working (forbidden) area. Therefore, the supply current of the fan must be checked during heat exchange mode as well as during bypass mode.
- Air filters must be installed in front of the cold and hot air inlets to avoid fouling of the heat-exchange surfaces, successive reduction of the heat exchanger effectiveness, and increasing pressure losses.

#### Handling and Transport

- Handling and transport of the chamber must always be performed in the horizontal position, i.e., with the by-pass channel situated upwards, on a flat surface (e.g., pallet + cardboard box).
- Lifting must be performed using the lower corners of the casing, respectively the lower edges of the chamber.
- The chamber structure allows 3 chambers to be stacked during transport. Cardboard must always be inserted between the chambers.
- The support area of the chamber is created by the corners and perimeter of the chamber. Therefore, **do not place** smaller items on the cover of the chamber – **risk of breakage of the chamber cover and area around the by-pass channel.**
- **The heat exchanger is made of thin aluminium profiles. Any unqualified handling can cause permanent and irreparable damage.**

### KFD, VFK dust filter, VFT grease filters

#### Operating Conditions a poloha

Filter should be installed in the air-handling duct at the beginning of the assembly (always in front of the exchangers, heat exchanger, and fan). The horizontal or vertical (the air flow direction downright) positions are recommended. The filters are designed for indoor use. When installed outside, they must be protected against water by a cover. Transported air must be free of corrosive substances or chemicals aggressive to zinc and rubber. Acceptable temperature of transported air can range from -30°C to +70°C..

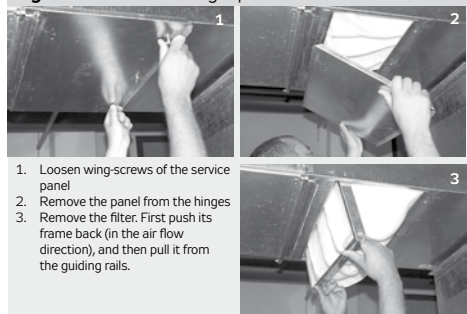
#### Installation

The filter cassettes must be installed in the air-handling duct so that the air-flow direction through the filter will follow the arrow on the casing. Before installation, paste self-adhesive sealing onto the connecting flange face. To connect the filter flanges, use galvanized screws and nuts M8 (M10 only for KFD 100-50). It is necessary to ensure conductive connection of the flange using fan-washers placed on both sides at least on one flange connection. To brace the flanges with a side longer than 40 cm, it is advisable to connect them in the middle with another screw clamp which prevents flange bar gapping. The removable inspection panel must be easily accessible. If installed into a ceiling, space for the inspection panel opening and filter replacing must be taken into account.

#### Service and maintenance (dust filters)

The filters require regular inspection for fouling and replacement, if necessary. Inspection and filter replacement can be performed after loosening the wing screws and removing the service panel from the cassette casing. The filter can be removed in the following way:

**Figure 59 – Filtration bag replacement**

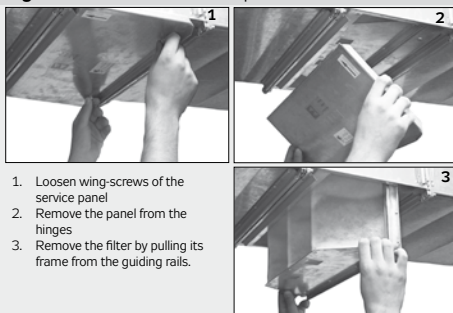


1. Loosen wing-screws of the service panel
2. Remove the panel from the hinges
3. Remove the filter. First push its frame back (in the air flow direction), and then pull it from the guiding rails.

First push its frame back (in the air flow direction), and then pull it from the guiding rails. Place the new filter following the reverse way (Figure 47, 48).

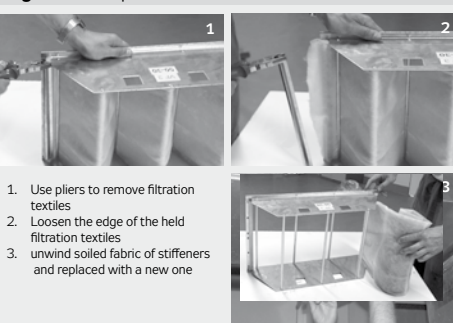
Filter fabric replacement of the insert filter can also be performed without changing the supporting structure of the insert. For replacement procedure see F(igure 49).

**Figure 60 – Filtration insert replacement**



1. Loosen wing-screws of the service panel
2. Remove the panel from the hinges
3. Remove the filter by pulling its frame from the guiding rails.

**Figure 49 – replacement of the filter fabric**

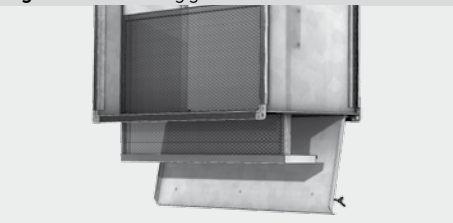


1. Use pliers to remove filtration textiles
2. Loosen the edge of the held filtration textiles
3. unwind soiled fabric of stiffeners and replaced with a new one

#### Service and maintenance (grease filters)

VFT filter cartridge is equipped with a metal filter element and a tray for retaining the separated waste particles (greases, oils). Filter tray can be pulled out (like dust filters) and cleaned. Filter elements can be removed from the section after washed with hot water (max 80 °C) and detergent. Respectively, highly contaminated filter element can be replaced with a new one.

**Figure 61 – Removing grease filter**



For more detailed information on technical parameters and also filter (cartridge) recovery see Vento duct units catalogue, eventually consult filter replacement parts with the manufacturer.

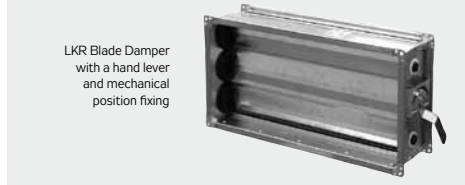
### Blade Dampers

#### LKR Manual Blade Dampers

##### Operating Conditions

LKR blade dampers are designed for outdoor application in air flow free of solid, fibrous, sticky or aggressive impurities..

**Figure 62** – LKR Blade Damper



#### LKS Driven Blade Dampers

##### Operating Conditions

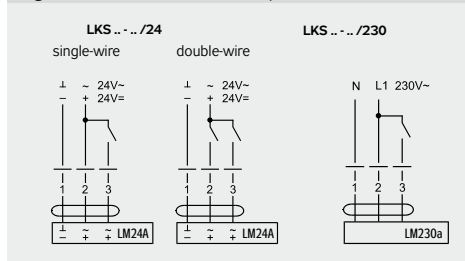
The LKS blade dampers are designed for outdoor applications in air flow free of solid, fibrous, sticky, aggressive or explosive impurities.

##### Installation, Maintenance and Service

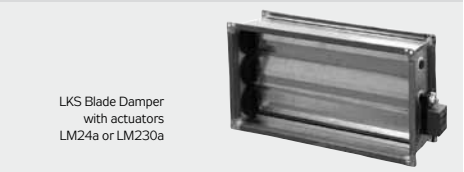
Before installation, paste self-adhesive sealing onto the connecting flange face. To connect the damper flanges, use galvanized screws and nuts M8 (M10 only for dimensions 90-50 and 100-50). It is necessary to ensure conductive connection of the flange using fan-washers placed on both sides at least on one flange connection. To brace the flanges with a side longer than 40 cm, it is advisable to connect them in the middle with another screw clamp which prevents flange bar gapping.

If installed into a ceiling, space for the opening enabling inspection of the actuator must be taken into account. The damper must not be exposed during installation or operation to any torsion. After installation, it is necessary check free movement of the blades by pressing the release button on the actuator. Deformed blades can cause increased resistance, and the actuator will be automatically stopped.

**Figure 52** – Connection of damper actuator



**Figure 53** – LKS Blade Damper



#### Lamel. klapky s pohonem LKSX

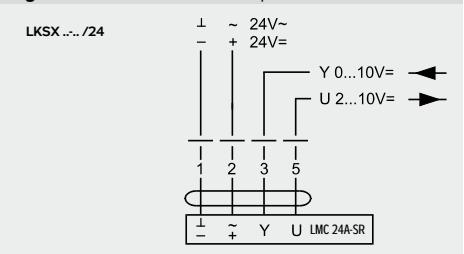
##### Operating Conditions

LKSX driven blade dampers are designed for outdoor application in air flow free of solid, fibrous, sticky or aggressive impurities.

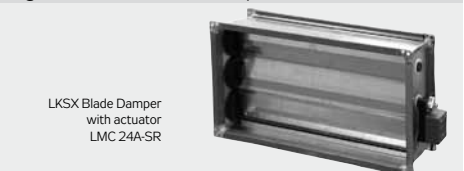
##### Installation, Maintenance and Service

Before installation, paste self-adhesive sealing onto the connecting flange face. To connect the damper flanges, use galvanized screws and nuts M8, for dimensions 90-50 and 100-50 use screws M10. It is necessary to ensure conductive connection of the flange using fan-washers placed on both sides at least on one flange connection. To brace the flanges with a side longer than 40 cm, it is advisable to connect them in the middle with another screw clamp which prevents flange bar gapping. If installed into a ceiling, space for the opening enabling inspection of the actuator must be taken into account. The damper must not be exposed during installation or operation to any torsion. After installation, it is necessary to check free movement of the blades by pressing the release button on the actuator. Deformed blades can cause increased resistance, and the actuator will be automatically stopped. The wiring connection can be performed via the wiring terminal box. The actuator is equipped with a 1m long 3 x 0.75 mm<sup>2</sup> cable.

**Figure 54** – Connection of damper actuator



**Figure 55** – LKSX Blade Damper



### Driven Blade Dampers / Mixing Sections

#### Lamel. klapky s pohonem LKSF

##### Operating Conditions

LKSF blade dampers are designed for indoor and outdoor use in air flow free of solid, fibrous, sticky, aggressive respectively explosive impurities.

##### Installation, Maintenance and Service

Before installation, paste self-adhesive sealing onto the connecting flange face. To connect the damper flanges, use galvanized screws and nuts M8 (for dimensions 90-50 and 100-50 use screws M10). It is necessary to ensure conductive connection of the flange using fan-washers placed on both sides at least on one flange connection. To brace the flanges with a side longer than 40 cm, it is advisable to connect them in the middle with another screw clamp which prevents flange bar gapping.

If installed into a ceiling, space for the opening enabling inspection of the actuator must be taken into account. The damper must not be exposed during installation or operation to any torsion. After installation, it is necessary to check free movement of the blades by pressing the release button on the actuator. Deformed blades can cause increased resistance, and the actuator will be automatically stopped. The wiring connection can be performed via the wiring terminal box. The actuator is equipped with a 1m long 2 x 0.75 mm<sup>2</sup> cable..

Figure 56 – Connection of damper actuator

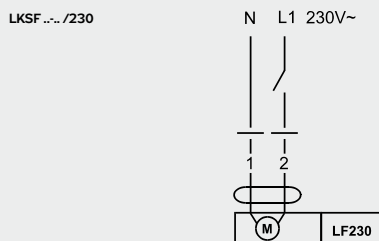


Figure 57 – LKSF Blade Damper

LKSF Blade Damper with actuator and emergency function



#### SKX Mixing Sections

##### Operating Conditions

Mixing sections are designed for indoor and outdoor applications in air flow free of solid, fibrous, sticky, aggressive respectively explosive impurities.

##### Installation, Maintenance and Service

Before installation, paste self-adhesive sealing onto the connecting flange face. To connect the flanges use galvanized screws and nuts M8. It is necessary to ensure conductive connection of the flange using fan-washers placed on both sides at least on one flange connection. To brace the flanges with a side longer than 40 cm, it is advisable to connect them in the middle with another screw clamp which prevents flange bar gapping. If installed into a ceiling, space for the opening enabling inspection of the actuator must be taken into account. The mixing section must not be exposed during installation or operation to any torsion. After installation, it is necessary to check free movement of the blades by pressing the release button on the actuator. Deformed blades can cause increased resistance, and the actuator will be automatically stopped. The wiring connection can be performed via the wiring terminal box. The actuator is equipped with a 1m long 3 x 0.75 mm<sup>2</sup> cable.

Figure 58 – Actuator connection

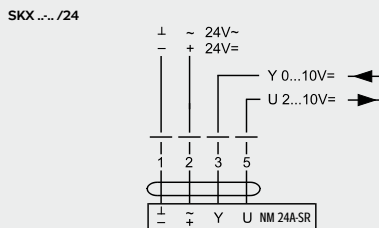


Figure 59 – SKX Mixing Section

SKX Mixing Section with actuator



## Noise Attenuators / Drop Eliminators

### TKU Attenuators

#### Operating Conditions

TKU attenuators are designed for direct installation into square air ducts. They are intended for indoor use (when installed outside, they must be protected against water by a cover). Transported air must be free of solid, fibrous, sticky, aggressive impurities. Maximum air flow speed among splitters can be 20 m/s.

If possible, we recommend putting a 1-1.5 m long duct in front of the attenuator to balance partly the speed profile of the air flow. Two successive attenuators can be used to increase insertion loss.

#### Installation, Maintenance and Service

Before installation, check the surface condition of attenuation splitters, and paste self-adhesive sealing onto the connecting flange face. To connect the damper flanges, use galvanized screws and nuts M8, for dimensions 90-50 and 100-50 use screws M10. It is necessary to ensure conductive connection of the flange using fan-washers placed on both sides at least on one flange connection. To brace the flanges with a side longer than 40 cm, it is advisable to connect them in the middle with another screw clamp which prevents flange bar gapping.

**If two successive attenuators are installed, they must be interconnected by the sides where the faces of the splitters match with the flange edge!**

Figure 60 – TKU Attenuator



### EKP Drop Eliminators

#### Operating Conditions, poloha

Flowing air must be free of solid, fibrous, sticky, aggressive impurities, and without corrosive chemicals or chemicals aggressive to zinc.

Installation position must allow correct function of the condensate flow - recommended is horizontal.

#### Installation

The installation, servicing and maintenance can be performed only by a specialized company possessing the appropriate tools.

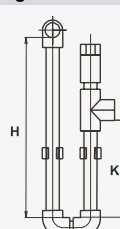
- There is no need for individual suspensions to install the EKP drop eliminator. The drop eliminator can be inserted into the duct line, but it must not be exposed to any strain or torsion caused by the connected duct line.
- Before installation, paste self-adhesive sealing onto the connecting flange face. To connect individual parts of the Vento system, use galvanized screws and nuts M8. It is necessary to ensure conductive connection of the flange using fan-washers placed on both sides at least on one flange connection, or use Cu conductor wiring.

Figure 61 – Drop eliminator description



- 1 outer casing, 2 drop eliminator,
- 3 condensate drain, 4 condensate outlet

Figure 62



H (mm)	K (mm)	P (Pa)
100	55	600
200	105	1100
260	140	1400

H... siphon height  
K... siphon drain height  
P... total pressure of the fan

### Condensate Draining

The eliminator is equipped with condensate collection tub, finished with an outlet for condensate draining connection kit. Draining condensate kits are only available as separately ordered accessories. The siphon height depends on the total pressure of the fan and ensures its proper function. The siphon must be designed according to the fan pressure (Figure 62).

### Pressure Dampers / Louvers

#### PK Pressure Dampers

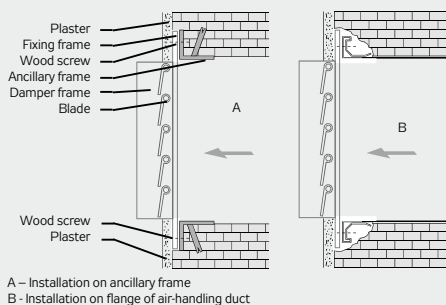
##### Operating Conditions

The PK pressure damper is intended to be situated vertically on the air exhaust. Transported air must be free of solid, fibrous, sticky, aggressive impurities. Maximum air flow speed can be 6 m/s.

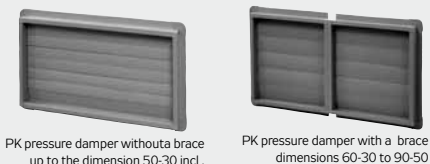
##### Installation

The standard version of the PK pressure damper must be installed with the longer side in the horizontal position while the blades are closed automatically (by gravity). The acceptable air flow direction is indicated in figure #60. The pressure damper can be fixed with wood or self-tapping screws to an ancillary wooden or steel frame, respectively to the flange of the air-handling unit. If used on a façade, it must be embedded 2 cm into the façade to cover its fixing frame.

**Figure 63 – Installation of PK Pressure Damper**



**Figure 64 – PK Pressure Dampers**



#### PZ Louvers

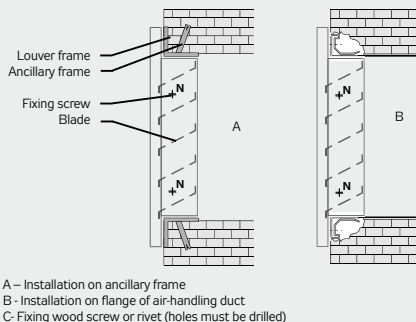
##### Operating Conditions

PZ louvers are designed for outdoor use. The louver must be installed vertically on the façade, on the exhaust or intake of the air-handling duct. Transported air must be free of solid, fibrous, sticky, aggressive impurities. Maximum air flow speed can be 6 m/s.

##### Installation

The standard version of the PZ louver must be installed with the longer side (blades) in the horizontal position. It can be fixed with wood or self-tapping screws to an ancillary wooden or steel frame, respectively riveted to the air-handling duct wall. Holes for fixing elements (wood or self-tapping screws, rivets) must be drilled into the louver side (see fig #65).

**Figure 65 – Installation of PZ louver**



**Figure 66 – PZ Louver**





### DV Elastic Connections / EP Flanges

#### DV Elastic Connections

##### Operating Conditions

Elastic connections can be used up to a pressure of 3000 Pa. They are not designed for mechanical loading, and cannot be used as a supporting part of the duct. The construction length is 155 mm, while the usable mounting (planning) length is 120 mm.

##### Installation, Maintenance and Service

Before installation, paste self-adhesive sealing onto the connecting flange face. To connect the flanges, use galvanized screws and nuts M8, for dimensions 90-50 and 100-50 use screws M10. It is necessary to ensure conductive connection of the flange using fan-washers placed on both sides at least on one flange connection. To brace the flanges with a side longer than 40 cm, it is advisable to connect them in the middle with another screw clamp which prevents flange bar gapping. The elastic connection must not be mechanically loaded during operation.

If installed into a ceiling, space for inspection must be taken into account. Usually once a year, the elastic connections must be checked for tightness of the elastic insert and flexibility of the PVC band.

#### DK Elastic Connections

##### Operating Conditions

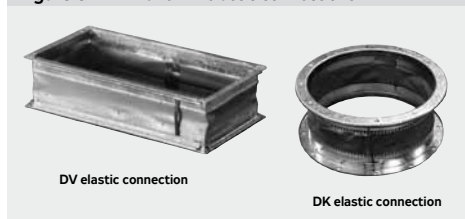
The same as DV elastic connections.

##### Installation, Maintenance and Service

Before installation, paste self-adhesive sealing onto the round connecting flange face. To connect the flanges, use galvanized screws and nuts M8 for dimensions up to 355, for dimensions from the 400 and up use screws M10. It is necessary to ensure conductive connection of the flange using fan-washers placed on both sides at least on one flange connection. The elastic connection must not be mechanically loaded during operation.

If installed into a ceiling, space for inspection must be taken into account. Usually once a year, the elastic connections must be checked for tightness of the elastic insert and flexibility of the PVC band.

Figure 67 – DV and DK elastic connections



#### EP Flanges

##### Installation

These flanges can be mounted on the free ends of a square duct of corresponding dimensions using self-tapping screws or rivets. They must be sealed with permanently flexible cement.

Figure 68 – EP Flange

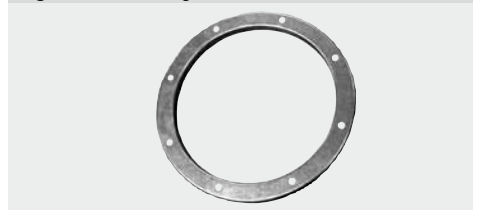


#### GK Flanges

##### Installation

These flanges can be mounted on the free ends of a round duct of corresponding diameter using self-tapping screws or rivets. They must be sealed with permanently flexible cement.

Figure 69 – GK Flange



### Steam humidifying

#### VLH chamber and steam humidifiers

##### Operating Conditions, Position

VLH chambers and steam humidifiers are designed for indoor installation, for humidification of air free of any chemicals that corrode or degrade zinc or solid contaminants (dust, etc.).

Location of VLH chamber must be horizontal in order to ensure proper pitch of pipe steam distribution pipes and condensate draining.

##### Installation, Maintenance, Service

When installing into duct system, VLH chamber distribution pipe should be pre-assembled first to ensure its correct position according to the unit instructions and then mount VLH chamber in the pipeline, ensuring a horizontal position. Installation of the chamber into the duct is similar to other components of the duct system - by means of flanges and ceiling hanging or on the supporting construction.

VLH chamber has removable tanks for condensate collection, it is therefore necessary to ensure service access and enough room, they need regular inspections to keep it clean, eventually treat any damage to the galvanized plate with a protective coating (settling impurities promote the formation of corrosion).

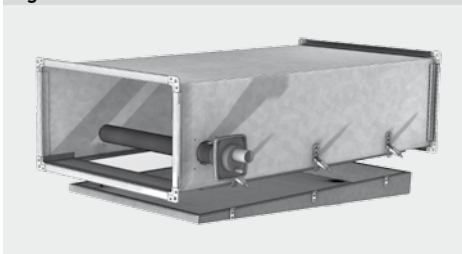
VLH chamber is equipped with a bottom outlet for condensate draining with G ½ thread, which is necessary to fit with an appropriate siphon depending on the pressure conditions in the chamber (similar to the coolers and HRV).

Information on installation, connecting, operation and maintenance of steam humidifier are included in the documentation delivered with the humidifier.

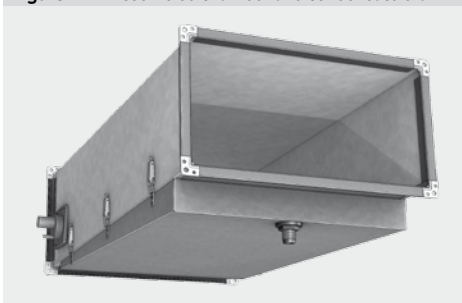
**Figure 70** – Generator unit and a distribution pipe



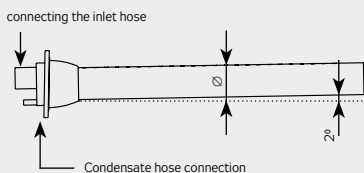
**Figure 71** – Visualization humidification chamber



**Figure 72** – Assembled chamber and condensate drain

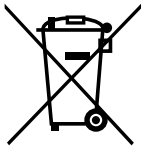


**Figure 73** – slope and distribution pipes connecting



## Additional information

### Disposal and Recycling



#### Information for disposal in other countries outside EU

Observe the applicable local environmental protection and waste disposal regulations.

#### For users from EU countries

When disposing of components and materials, observe Directive No. 98/2008/EU and its subsidiary Directive No. 2012/19/EU, applicable national and local environmental protection and waste disposal regulations.



It is always necessary to take into account local legislation and regulations.



Vento duct air handling units, including their individual parts, are not intended for direct sale to customers, respectively users. They are sold exclusively to specialized installation companies within the scope of commercial relations.

#### Notice

*The manufacturer reserves the right to make changes of document as a result of technical innovations and legislative conditions without prior notice.*

*Printing and language mistakes are reserved.*

*These Installation and Operating Instructions (as a whole or a part) must not be printed or copied without prior written permission from REMAK a. s., Zuberská 2601, Rožnov pod Radhoštěm, Czech Republic*

*These Installation and Operating Instructions are the sole property of REMAK a. s.*

*Changes reserved*

*Issued: 14th September, 2022*

# REMAK

REMAK a.s.

Zuberská 2601, 756 61 Rožnov pod Radhoštěm,  
tel.: +420 571 877 778, fax: +420 571 877 777,  
email: [remak@remak.eu](mailto:remak@remak.eu), internet: [www.remak.eu](http://www.remak.eu)

