

Roof Fans

RF Series

Contents

Basic Technical Information.....	3
Dispatch and Handling.....	4
Installation.....	5
Wiring	6
Commissioning.....	9
Accessory	11
Operating and Maintenance Instructions.....	13
Troubleshooting	16

General Information

- Vento duct air handling units are manufactured in accordance with valid Czech and European regulations and technical standards.
 - Vento duct air handling units must be installed and used only in accordance with this documentation. The manufacturer is not responsible for any damages resulting from use other than intended, and the customer bears the risks of such use.
 - The installation and operating documentation must be available for the operating and servicing staff. It is advisable to store this documentation close to the Vento unit.
 - When handling, installing, wiring, commissioning, repairing or servicing the air handling units, it is necessary to observe valid safety rules, standards and generally recognized technical rules. In particular, it is necessary to use personal protective work aids (e.g. gloves) because of sharp edges and corners when performing any handling, installing, dismantling, repairing or checking.
- All equipment connections must comply with the respective safety standards and regulations.
- Any changes or modifications to individual components of the Vento duct system which could affect its safety and proper functioning are forbidden.
 - Before installing and using the air handling units, it is necessary to familiarize yourself with and observe the directions and recommendations included in the following chapters.
 - **Vento air handling units, including their individual parts, are not intended, due to their concept, for direct sale to end customers. Each installation must be performed in accordance with a professional project created by a qualified air-handling designer who is responsible for the proper selection and dimensioning of components concerning their suitability for a given application. The installation and commissioning may only be performed by an authorized company licensed in accordance with generally valid regulations.**
 - When disposing of components and materials, it is necessary to observe the respective environmental protection and waste disposal regulations. In case of final device liquidation, it is necessary to follow the policy of differential waste disposal. We recommend metal parts be scrapped and other parts be disposed of in accordance with separated waste regulations.
 - Further information can be found in the „Duct Units“ Catalogue and in the AeroCAD design software.
 - **The latest version of this document is available on our website: www.remak.eu**

Basic Technical Information

Manufacturer's Notification

The roof fans with vertical outlet are intended for air exhaust from a room with normal environment in accordance with the chapter „Application and Operating Conditions“. When planning the fan for the required air flow and pressure, the following general rule is applied; fan motors with a greater number of poles reach the required parameters at lower RPM, which results in lower noise and longer service life. The standard dimensional and performance range of single-phase and three-phase RF fans enables designers to optimize all parameters for air flow rates from 300 m³/h up to 14,000 m³/h. Using a suitable roof adaptor (optional), the fan can be situated on flat as well as sloping roofs.

■ When disposing of components and materials, it is necessary to observe the respective environmental protection and waste disposal regulations. In case of final device liquidation, it is necessary to follow the policy of differential waste disposal. We recommend metal parts be scrapped and other parts be disposed of in accordance with separated waste regulations.

■ Any changes or modifications to the product which could affect its safety and proper functioning are forbidden.

Application and Operating Conditions

■ Application and Operating Conditions. The device can be used in normal rooms (IEC 60364-5-51, respectively ČSN 33 2000-5-51 ed. 3, ČSN 33 2000-1 ed. 2) extended for outdoor areas and in areas exposed to weather effects with ambient temperature ranging from -30 °C to +40°C without additional measures.

■ The fan may only be used to transport air without solid, fibrous, sticky, aggressive or explosive impurities. The transported air must be free of corrosive chemicals or chemicals aggressive to zinc, aluminium or plastics. Maximum permissible temperature of the transported air must not exceed +40°C (three-phase fans), respectively +60°C (single-phase fans).

■ RF fans can only be operated, transported or stored in the basic horizontal position.

Motor Protection

■ As standard, permanent monitoring of the internal motor temperature is used in all motors. The permissible limit temperature is monitored by thermo-contacts which after being connected to the protective contactor circuit protect the motor against overheating due to phase failure, forced motor braking, current protection circuit breakdown or excessive temperature of the transported air. Thermal protection by means of thermo-contacts is comprehensive and reliable providing they are correctly connected. This type of protection is essential especially for speed controlled and frequently started motors and motors highly thermally loaded by hot transported air.

Serial Thermo-Contact (self-acting)

The motor thermo-contact connected in series to the motor winding will disconnect the power supply if the winding temperature exceeds +130°C. After cooling down, the thermo-contact closes, and the fan will start. All RF 40/xx and RF 56/31-4E fans are equipped with serial thermo-contacts.

Beware of possible automatic fan start when servicing the fan! The fan must be disconnected from the power supply when working on it (uncovered outlet pockets)! Application of this operational behaviour (non-signalled shutdown) must be evaluated within the scope of the air-handling device project.

Brought-Out Thermo-Contact (control)

Fans equipped with a thermo-contact brought out into the terminal box (TK- TK terminal) must be connected to the recommended protective device. When the temperature exceeds critical values, the thermo-contact will disconnect the control circuit of the protective device, which will further disconnect the motor power supply. The motor restart must be conditioned by the operator's interference, check and removal of the protective shutdown causes. Repeated restart of the motor without removing the cause of the motor overheating results in shorter service life of the product, or can damage the motor. All fans, except the RF 40/.. and RF 56/31-4E lines, are equipped with brought-out thermo-contacts. Maximum thermo-contact permanent loading is 1.2 A at 250V/50Hz (cos φ 0.6), (respectively 2 A at cos φ 1.0). Fan motors with brought-out thermo-contacts cannot be protected by conventional over-current protection! Only protection using thermo-contacts is comprehensive because it also covers high ambient/air temperature. Proper use of thermal protection is the most important condition for warranty validity.

Live and Non-Live parts Protection

Protection against Dangerous Contact with Live Parts

This protection is ensured by:

- Degree of protection in accordance with ČSN 33 2000-4-41 ed.2 (412.2)
- Insulation in accordance with ČSN 33 2000-4-41 ed.2 (412.1)

Protection against Dangerous Contact with Non-Live Parts

Automatic power supply cut-off (not included in the delivery, must be ensured during installation). Additional protection by interconnecting the non-live parts:

- Motor

The protective terminal to connect the motor to the protective conductor is situated inside the terminal box cover, and has a PE sign.

- Fan body

All fan body parts are conductively interconnected. The fan base is interconnected with the fan body using a separate yellow/green ground conductor. An M6 screw and nut with fan washers are situated on the fan body (outer side) to connect the ground conductor (see figure # 11).

Dispatch and Handling

Information and Safety Labels

- A „Warning – Danger of Electric Shock“ label is situated on the upper cover lid of the motor compartment.
- „Air Flow Direction“ label – an arrow pointing up is situated in the upper area of the outlet pocket side.
- The ground point screws are marked with ground symbol labels.
- The wiring connection label is situated on the inner side of the terminal box cover.
- The rotation direction label is situated on the motor bracket.
- The lift hook symbol label is situated on the support side plate next to the handling holes.

Dispatch List, Documentation

Along with the fan, the delivery includes the following:

- The fan base and roof adaptor sealing strip
- 2 pcs - plastic plugs to seal the lifting holes
- 4 pcs - M8x30 screws with washers
- 4 pcs - M8 screw plastic caps

Further, the package includes:

- Installation Instructions

Packaging (design)

RF 40: Double-wall corrugated board box

RF 56: Double-wall corrugated board box

RF 71: Double-wall corrugated board box

RF 100: Wooden crate on a pallet

Transport and Storage

Storage Conditions

The product must be stored in indoor areas complying with the following condition:

- Maximum relative air humidity must not exceed 85%.
- Without moisture condensation.
- Ambient temperature must be within the range -20°C to +40°C.
- The air-handling unit must be protected against penetration of dust and caustic vapours, or other chemical substances which could cause corrosion of the air-handling unit's structural components

Stacking

RF 40: Max. 5 rows on a firm pallet (800x1200 pallet:

4 pcs per row) RF 56: Max. 5 rows on a firm pallet

(800x1200 pallet: 2 pcs per row) RF 71: Max. 2 rows

on a firm pallet (800x1000 pallet: 1 pc per row or

1000x1600 pallet: 2 pcs per row)

RF 100: Max. 2 pcs (1440x1200x1100 pallet with a wooden crate)

Transport and Handling

- Only means intended for this purpose can be used to transport, lift or handle the product.
- Only packed products on a pallet may be transported.
- Unpacked products can be lifted on the installation site. For this purpose, the 29mm holes for lifting hooks situated on the upper part of the fan can be used, or it

can be handled manually suspended on a rod (see figure # 2).

- Depending on the product weight, it can be transported manually providing personal protective aids are used. Do not lift or carry the fan using outlet pockets.
- Attention! There is a greater risk of damage to the product if unpacked!
- When handling the product, pay attention to the risk of it dropping followed by damage to the product!

Figure 1 – Information and Safety Labels

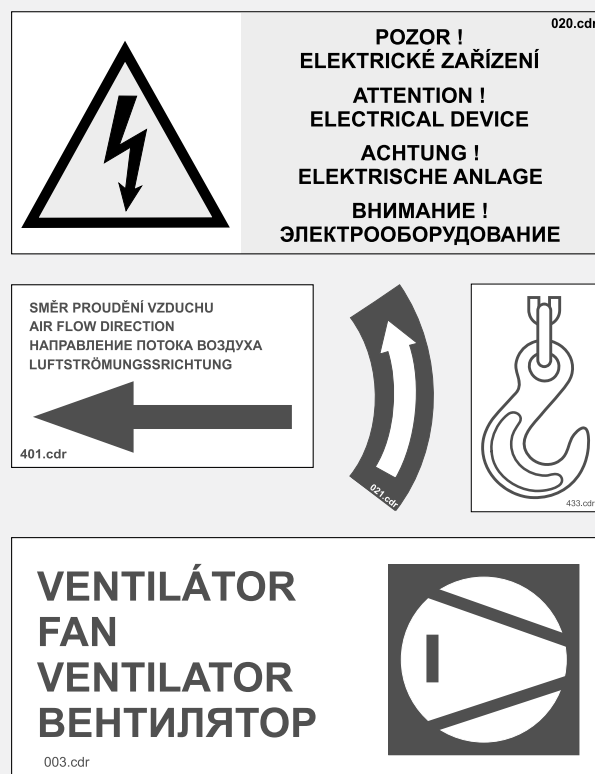
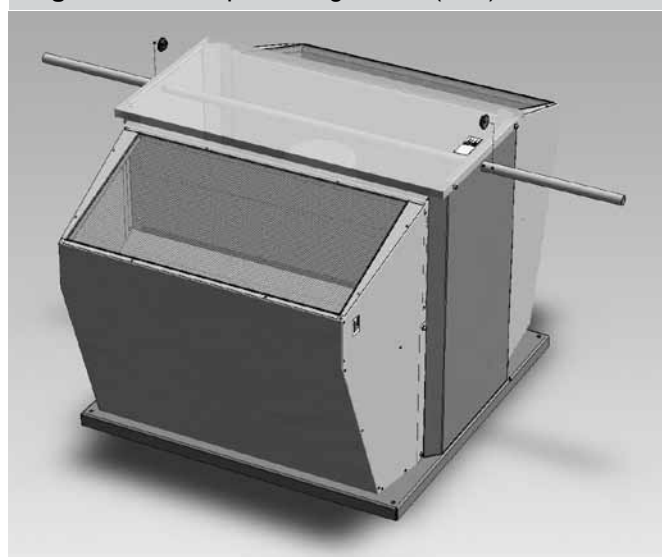

Figure 2 – Transport using 28mm (3/4") rod



Installation

Location Instructions

- The installation site must comply with the conditions required for a particular product (refer to the chapter „Application and Operating Conditions“).
- Safe access to the equipment must be ensured to enable installation, maintenance or repairs.
- The fan is designed to be installed on a roof adaptor, including sloping roofs.
- RF fans can only work in the horizontal position (i.e. the impeller rotation axis is in the vertical position). Maximum permissible fan offset from the vertical axis:
 - Outlet openings situated crosswise to the roof slope: max. 5°
 - Outlet openings situated lengthwise to the roof slope: max. 5°

Figure 3 – Max. fan offset from the vertical axis

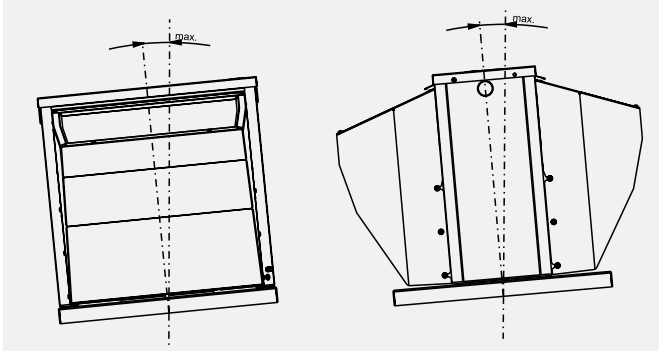

- The roof fans can only be installed on a suitable firm structure that can withstand the fan weight and weather effects expected in the installation site.
- The fan can draw in air directly from the ventilated room, or it can be connected to air ducting. The connected air ducting must not be suspended from the fan otherwise the fan base could become distorted. To connect the duct to the fan, use an elastic connection.
- A self-acting pressure damper connected to the fan intake prevents air backdraught. Air flow can cause condensate to form on the cool parts of the fan which then runs down.
- Poor insulation may cause leakages through which moist air can be drawn in on the fan inlet side (incl. roof adaptor).

Installation Procedure

The fan installation consists of several operations arranged according to the required qualification of the worker performing the installation and the logical sequence of operations.

Installation Safety Instructions

- Secure the installation site for safe movement of persons (e.g. specified scaffolding).
- Use suitable installation tools and secure them against falling from the roof.
- Observe general safety rules and instructions included in the device or premises operating instructions, and instructions for crane slingers and work at heights.

Pre-Installation Inspection

The fan must be checked carefully before installation, especially if it has been stored for a longer period. In particular, it is necessary to check all parts and cable insulation for damage, and to see whether the rotary parts can rotate freely. It is also necessary to check the ducting connected to the fan for undesirable objects. To identify the product properly, see the designations on the rating plate.

Fan Installation

- If the installation includes air-handling accessories (vacuum damper, elastic connection, duct extension, etc.), connect them from below to the fan base using nuts ready for this purpose. To do so, put the fan down on its side plate – to avoid scratching, put it on a clean and smooth surface (e.g. cardboard).
- The roof adaptor delivery includes an insulation plate; glue it onto the lower part of the fan base. Thus condensation can be avoided. Cut out an opening in the inlet under the diffuser.
- Apply the delivered sealing along the entire circumference of the roof adaptor contact surface. The contact surface must be even and clean; an uneven surface results in impeller offset, and the leakage results in moisture drawn into the air-handling ducting.
- Place a corresponding fan on the prepared roof adaptor (use a suitable hoisting device).
- Using the enclosed M8x30 screws and sealing washers, fix the fan to the roof adaptor.
- Cover the screw heads with caps. Remove the upper fan cover (refer to page 13).
- With three-phase motors, remove the side outlet pocket to make it easier to access the terminal box (refer to page 13).

Figure 4 – Fan connection to the roof adaptor

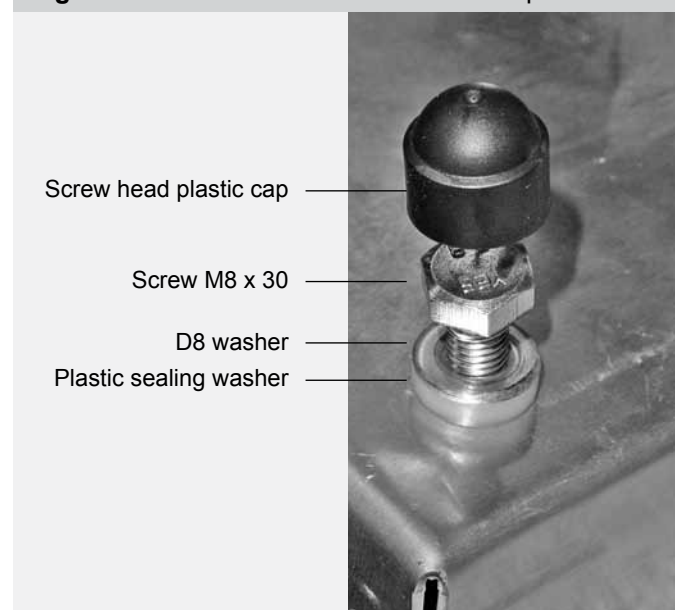

Wiring

Wiring

- The wiring can only be performed by a qualified worker licensed in accordance with valid regulations.
- For a description of protection by interconnecting, refer to the chapter „Live and Non-Live parts Protection“ (see page 3).

Control

Control of Single-phase Fans

- Stepless (thyristor) control, e.g. E2,5
- Voltage Control, e.g. TRN-E or TRRE

Control of Three-phase Fans

TAs standard, three-phase fans are equipped with IEC asynchronous motors with a short-circuit armature. The motor speed can be controlled by changing the frequency using a frequency inverter. It is advisable to connect the frequency inverter to the fan using a shielded cable, and make it as short as possible in accordance with the frequency inverter documentation. Power and control cables must be led separately.

Warning: If fans with frequency inverters 1x230V/3x230V, REMAK standard up to output of 0.75 kW, are used, it is necessary to reconnect the motors for AC 3x230V - Δ and verify, respectively adjust settings of motor nominal values in the frequency inverter. For wiring requirements, refer to Tables 1, 2 and the chapter Commissioning a three-phase fan with a frequency inverter.

The frequency inverter ensures over-current protection of the motor by disconnecting the power supply. The failure removal must be confirmed on the frequency converter to enable fan restart.

Terminal box

a) With single-phase motors, the wiring is terminated in the connecting terminal box, degree of protection IP 54. Wago terminals are used for single-phase motors

b) The three-phase motor terminal box is situated on the motor body. Connection is made using screw terminals. All terminal boxes are equipped with plastic bushings (grommets).

- Before connection, check the power supply network parameters for compliance with the data on the rating plate.
- Manually turning the impeller, check it for free rotation. Also check it for play.

Figure 5 – Wago terminal

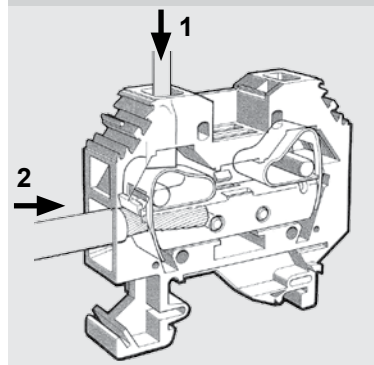

- Connect the power supply and thermal protection cables to the terminal box (verify whether the installed fan is equipped with a brought-out thermo-contact or not. The wiring connection to the terminals can be performed following the marking

on the motor cables, the description of terminals or the label on the terminal box lid.

Observe the following:

- Observe the motor wiring diagrams (see figs. #8, 9)
- **Check whether the motor is controlled by a frequency converter. The type of frequency inverter connection to the motor, 3x400V -Y or 3x230V- Δ, is included in table #1. Three-phase motors are always connected for 3x400V - Y voltage in the factory; if the fan is controlled using a 3x230V - Δ frequency inverter (motor outputs up to 0.75 kW,), it is necessary to reconnect the terminal box on the motor for delta connection! Fans with motors 1,5 kW and higher remain always connected for 3x400V - Y.**
- The wiring cables are led into the terminal box through the tube which is routed through the fan and roof adaptor interior into the ventilated room. The power supply cable and thermal protection cable must be led separately (see figure # 11, 12).

Figure 6 – Y/Δ connection in 3ph. motor terminalbox

Frequency inverter, IP54 (RFFMIBxxxx50)

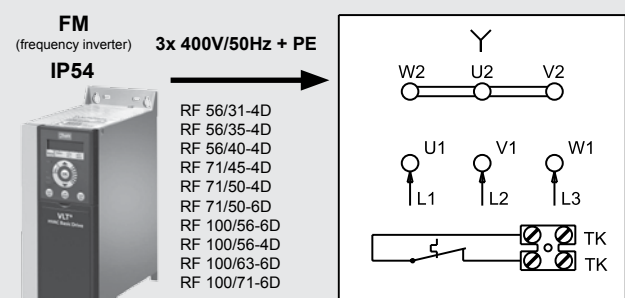
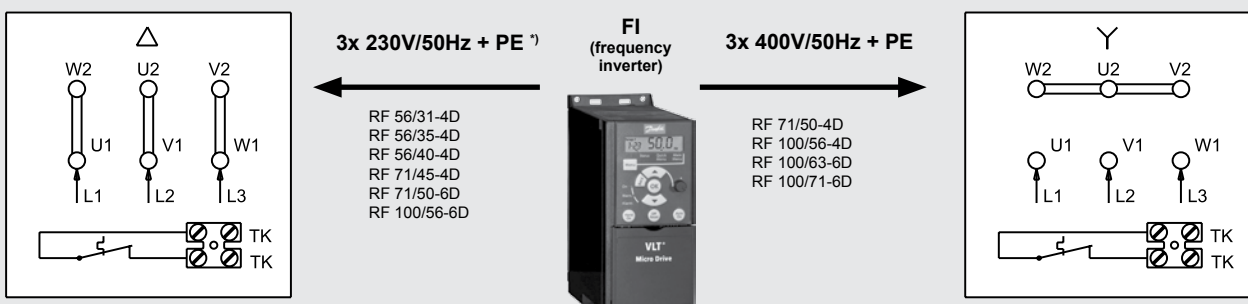

Figure 7 – Y/Δ connection in 3ph. motor terminalbox using frequency inverter, IP21 (RFFMIMxxxx20)



*) frequency inverter is delivered as a standard, see table #1, page 9)

Wiring

Figure 8 – RF fan basic wiring diagram

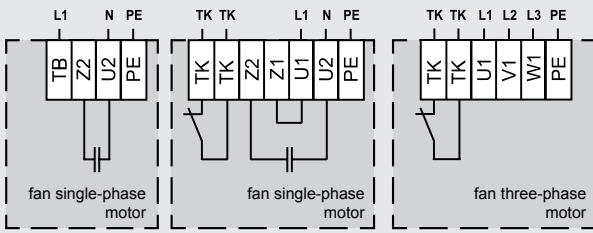

TB -- Single-phase power supply terminals
1f - 230V/50Hz
TK - Terminals of the motor thermo-contacts
U1, U2
- Single-phase power supply terminals
1f - 230V/50Hz
PE - Protective conductor terminal

TK - Terminals of the motor thermo-contacts
U1, V1, W1
- Three-phase motor power supply terminals 3f - 400V/50Hz
PE - Protective conductor terminal

Figure 9 – RF fan wiring diagram a) using frequency inverter, b) using TRN-E voltage controller

a) TRN-E voltage controller

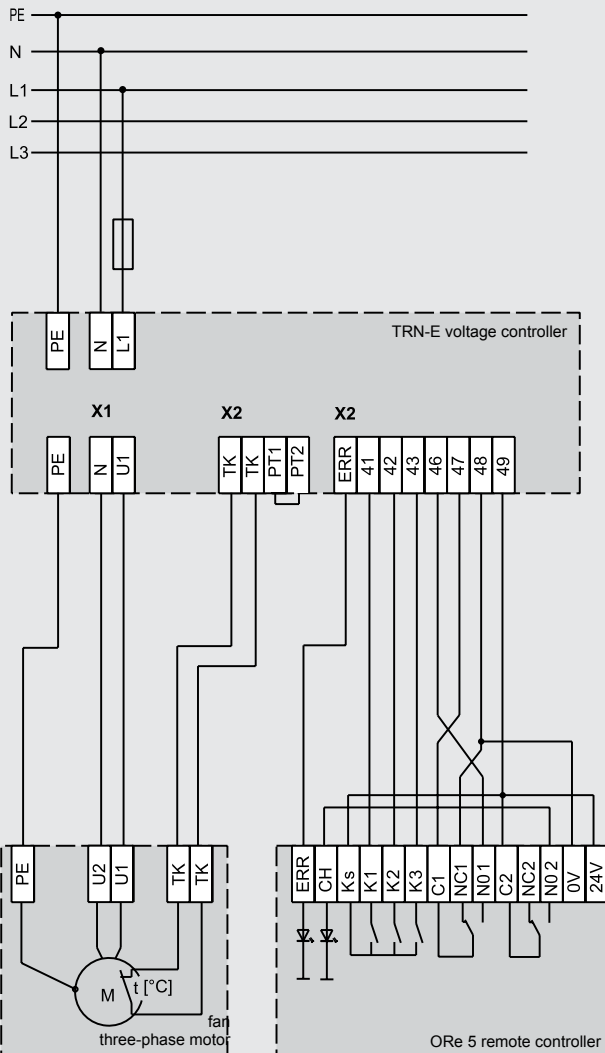

b) FC101 Basic 3F frequency inverter

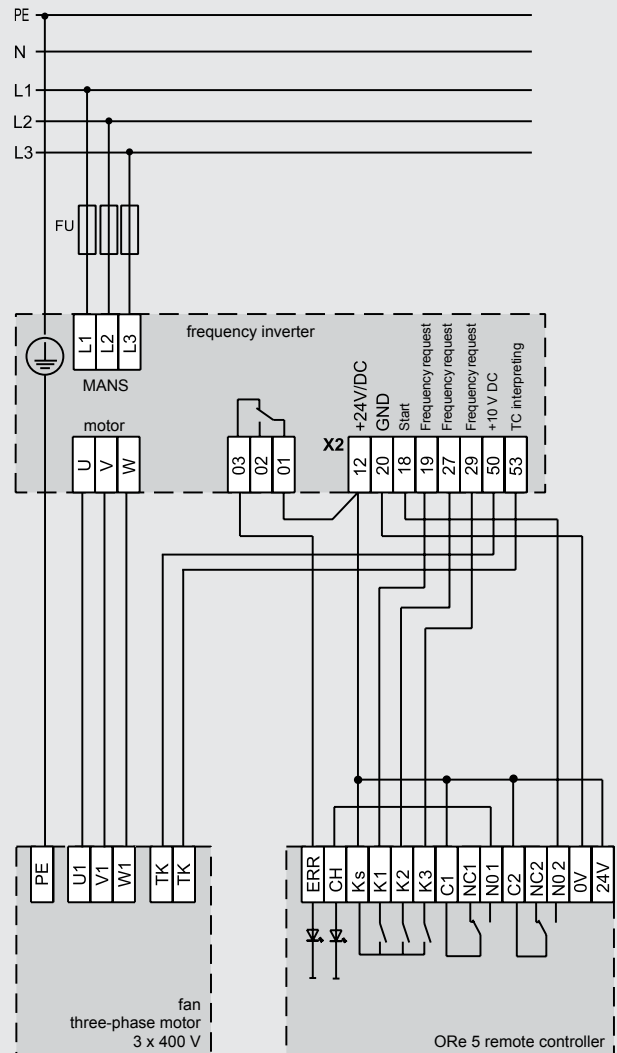

Wiring

Figure 10 – RF fan wiring diagram using frequency inverter

a) FC051 Micro 1F frequency inverter

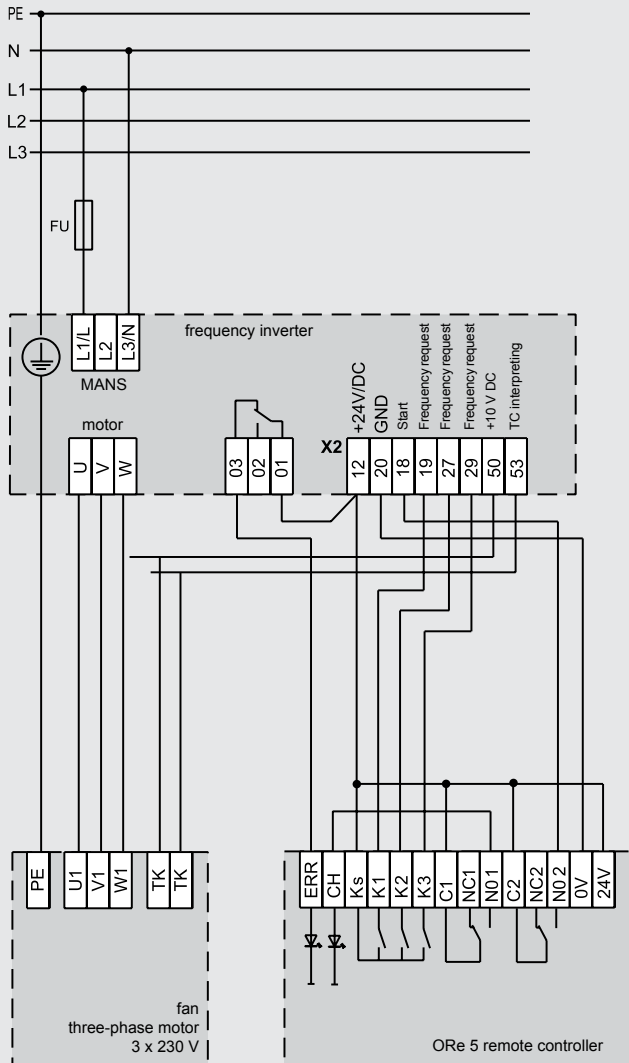

b) FC051 Micro 3F frequency inverter

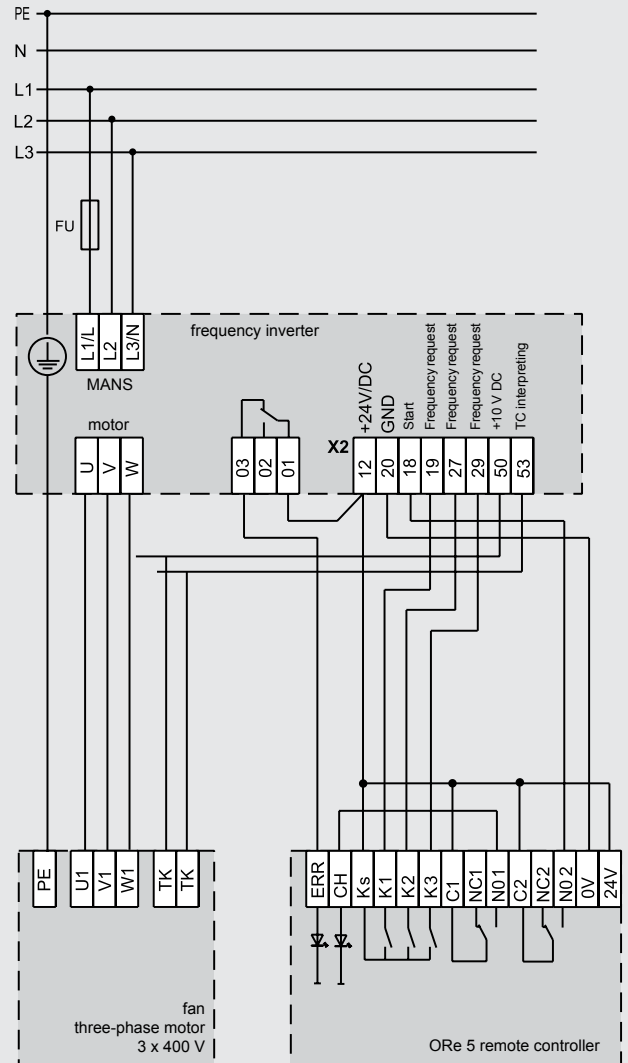

Wiring

■ When dimensioning the conductors, it is necessary to take into account the current loading by the device as well as the length of the conductor. The following cables are recommended to connect fan motors:

- HO5VVH2-F 2Ax0,75 thermo-contact circuit
- CYKY 3Cx ... single-phase motor power supply
- CYKY 4Bx ... three-phase motor power supply, without control (ON/OFF)
- CYKFY 4Bx ... shielded, three-phase motor
- / CMFM 4Bx ... power supply, FM control

■ If the fan is controlled using electronic components (e.g. PE controllers or frequency inverter) it is necessary to eliminate electromagnetic interference (EMC). To connect the fan to the frequency inverter, use the specified shielded cable.

- The fan wiring diagrams with front-end elements (protective relays, controllers, control units) are included in the Installation Instructions, respectively in the Aero-CAD project of the front-end elements.
- Remove foreign objects from the fan.
- Install and fix the outlet pocket back.
- Check the protective conductor interconnection.

Table 1 – Connection, protection and control

Fan	Current (A)	Starting current (I _s /I _n)	Thermocontact motor protection (TC)	Capacitor value (µF)	Operation without control	Operation with control
Single-phase motors (1x230V+N+PE/50Hz)						
RF 40/19-2E	0,24	0,5	serial TC	2	Switch	TRN 2E, TRRE 2, PE-2,5
RF 40/22-2E	0,4	0,8	serial TC	2,5	Switch	TRN 2E, TRRE 2, PE-2,5
RF 40/25-2E	0,9	1,7	serial TC	6	Switch	TRN 2E, TRRE 2, PE-2,5
RF 40/28-4E	0,5	1,2	serial TC	4	Switch	TRN 2E, TRRE 2, PE-2,5
RF 56/31-4E	0,6	1,2	serial TC	4	Switch	TRN 2E, TRRE 2, PE-2,5
RF 56/35-4E	1,7	3,7	brought-out TC	6	STE	TRN 2E, TRRE 2+STE, PE-5+STE
RF 56/40-4E	1,8	5	brought-out TC	10	STE	TRN 2E, TRRE 2+STE, PE-5+STE

Fan	Current (A)	Starting current (I _s /I _n)	Thermocontact motor protection (TC)	Operation without control
Three-phase motors – operation without control (Y 3x400V +PE/50Hz)				
RF 56/31-4D	0,4	4,4	brought-out TC	STD (Y 3x400V)
RF 56/35-4D	0,7	5,2	brought-out TC	STD (Y 3x400V)
RF 56/40-4D	1,3	5,2	brought-out TC	STD (Y 3x400V)
RF 71/45-4D	1,9	6	brought-out TC	STD (Y 3x400V)
RF 71/50-4D	2,7	6	brought-out TC	STD (Y 3x400V)
RF 71/50-6D	1,2	4,7	brought-out TC	VSD required ¹⁾
RF 100/56-4D	4,8	7	brought-out TC	STD (Y 3x400V)
RF 100/56-6D	1,7	4,7	brought-out TC	VSD required ¹⁾
RF 100/63-6D	3,1	5,5	brought-out TC	STD (Y 3x400V)
RF 100/71-6D	4,5	6,5	brought-out TC	VSD required ¹⁾

¹⁾ According to ErP 2013 directive it is necessary to use frequency inverter control

Fan	F.I. output kW	IP21 (FC 051) Frequency inverter					IP54 (FC 101) Frequency inverter				
		Motor connection with control **)		Frequency inverter			Motor connection with control **)		Frequency inverter		
		Voltage system *)	Current (A)	Frequency inverter model	Supply voltage	Max. input current (A)	Voltage system *)	Current (A)	Frequency inverter model	Supply voltage	Max. input current (A)
Three-phase motors – operation with control (Δ 3x230V +PE/50Hz or Y 3x400V+PE/50Hz)											
RF 56/31-4D	0.37	Δ 3x230V	0,8	RFFMIM031A20	1x 230V	6,1	Y 3x400V	0,4	RFFMIB073B50	3x 400V	2,1
RF 56/35-4D	0.37	Δ 3x230V	1,3	RFFMIM031A20	1x 230V	6,1	Y 3x400V	0,7	RFFMIB073B50	3x 400V	2,1
RF 56/40-4D	0.75	Δ 3x230V	2,6	RFFMIM071A20	1x 230V	11,6	Y 3x400V	1,3	RFFMIB073B50	3x 400V	2,1
RF 71/45-4D	0.75	Δ 3x230V	3,3	RFFMIM071A20	1x 230V	11,6	Y 3x400V	1,9	RFFMIB073B50	3x 400V	2,1
RF 71/50-4D	1.5	Y 3x400V	2,7	RFFMIM153B20	3x 400V	5,9	Y 3x400V	2,7	RFFMIB153B50	3x 400V	3,5
RF 71/50-6D	0.37	Δ 3x230V	2,2	RFFMIM031A20	1x 230V	6,1	Y 3x400V	1,2	RFFMIB073B50	3x 400V	2,1
RF 100/56-4D	2.2	Y 3x400V	4,8	RFFMIM223B20	3x 400V	8,5	Y 3x400V	4,8	RFFMIB223B50	3x 400V	4,7
RF 100/56-6D	0.75	Δ 3x230V	2,9	RFFMIM071A20	1x 230V	11,6	Y 3x400V	1,7	RFFMIB073B50	3x 400V	2,1
RF 100/63-6D	1.5	Y 3x400V	3,1	RFFMIM153B20	3x 400V	5,9	Y 3x400V	3,1	RFFMIB153B50	3x 400V	3,5
RF 100/71-6D	2.2	Y 3x400V	4,5	RFFMIM223B20	3x 400V	8,5	Y 3x400V	4,5	RFFMIB223B50	3x 400V	4,7

*) Voltage system: 3x 230V +PE/50Hz, 3x 400V+PE/50Hz
 **) Connection of the motor with control delivered as standard accessor

Installation and Commissioning

Device Grounding

Conductively interconnect the fan to nearby metal structures. Use the marked ground screw. The ground conductor dimension, colour and marking must comply with applicable standards.

Figure 11 – Cable routing through the grommets

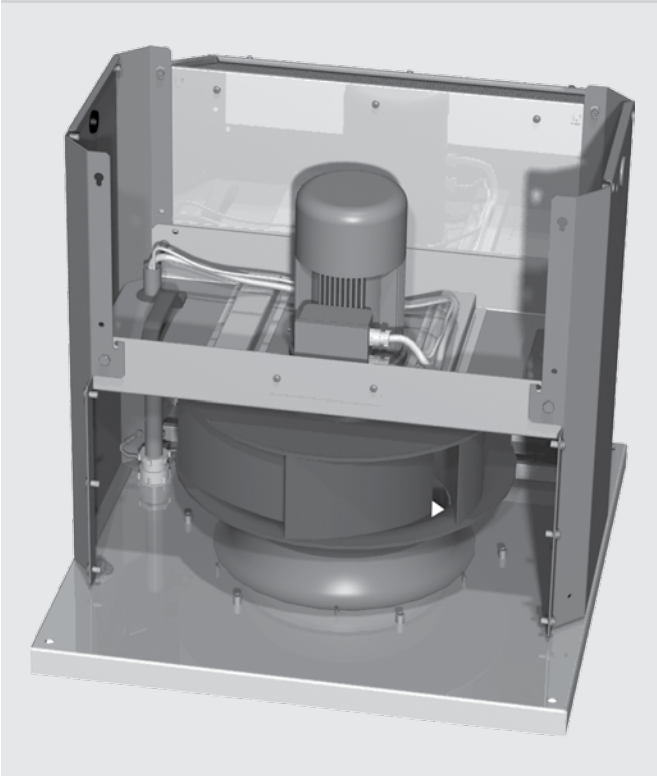

Figure 12 – Ground screw

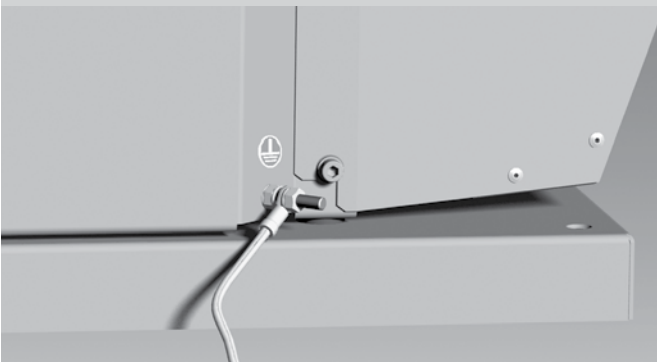
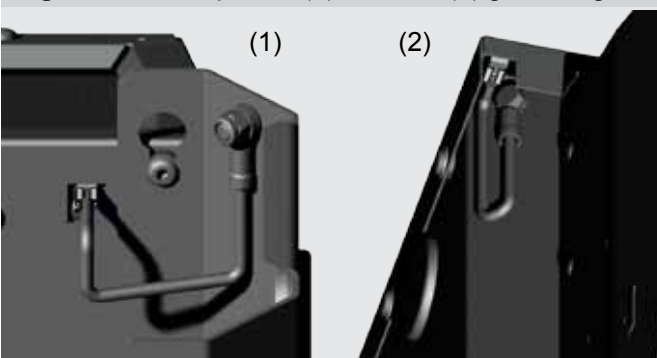

Figure 13 – Fan pocket (1) and roof (2) grounding



Installation and Connection Check

Before the first start-up, check the following:

- Check the air ducting and fan for completeness and damage.
- Check the screwing of all electric components.
- Inspect the motor thermal protection connection (according to the motor type, refer to the chapter „Motor Protection“, see page 3)
- Check all safety measures are applied (e.g. grounding insulation resistance).
- If the painted part surfaces have been blemished, repair the damaged spots with suitable anticorrosive paint.

Commissioning

- Only trained personnel may perform commissioning.
- When commissioning, observe all the safety rules and procedures included in this Operating Instructions.
- Attention! Rotating part injury danger!
- Avoid contact with outlet air.

Figure 14 – Open damper using Allen wrench No. 6

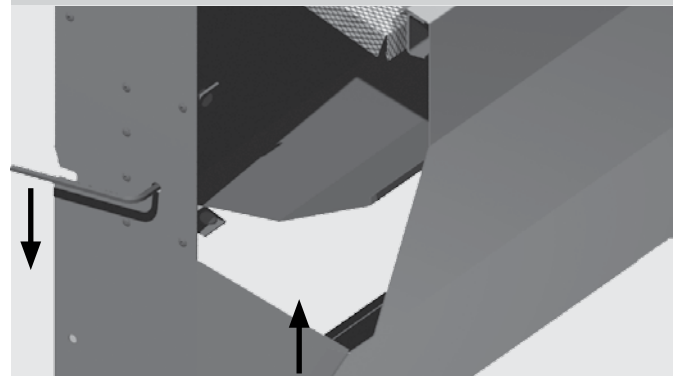

At first start-up, perform the following checks:

- With fans equipped with three-phase motors, check the proper direction of the impeller rotation following the direction of the arrow on the fan body. Briefly switch on the fan. Insert Allen wrench No. 6 into the damper pivot (through the side hole in the outlet pocket), and gently open the damper. Check the direction of the impeller rotation - the proper impeller direction of rotation is counter clockwise, looking from above. Otherwise, the fan output is significantly reduced, and the fan can be damaged. Reverse the motor poles by swapping two phases in the terminal box.
- Switch on the fan. Check the fan for unusual noises, impeller catching and stopping at start. The fan body must show no vibration.
- After starting the fan, the current must also be measured, and it must not exceed the maximum allowed current I_{max} stated on the rating plate. If the measured values exceed the allowed value, perform duct system regulation (i.e. create artificial pressure loss), or change (decrease) the frequency inverter frequency. Check the operation at all possible speed stages. The measured operating values must be recorded in a commissioning report.
- Check the functionality and gravity closing of the dampers.

Installation and Commissioning

Commissioning a three-phase fan with a frequency inverter

Four output ranges of Danfoss FC051 (VLT Micro) and three output ranges of Danfoss FC-101 (VLT HVAC BASIC) with higher degree (IP54) of protection frequency inverters (further in the text as FI) are used to control the output of RF fans; each FI can be used to control fans of different output ranges. Both FI types are intended for use in normal rooms (IEC 60364-5-51, respectively ČSN 33 2000-5-51 ed. 3) and each particular FI can control various lower output motors.

FI parameter set-up (current and output) is carried out in the factory to the roof fan's lowest output in the given fan output range. Before starting the roof fan, it is necessary to check the parameters on the rating plate (respectively the parameters from Table # 2) against the parameter set-up on the FI, respectively change the settings using the FI control panel, if necessary. The following parameters are concerned:

- Motor output – parameter number 1-20
- Motor current – parameter number 1-24
- Rated speed – parameter number 1-25

Frequency inverter control panel description

Indicators:

- Green indicator: indicates the inverter is powered.
- Yellow indicator: indicates a warning.
- Red flashing indicator: indicates a failure.

Figure 15 – Frequency inverter control panel

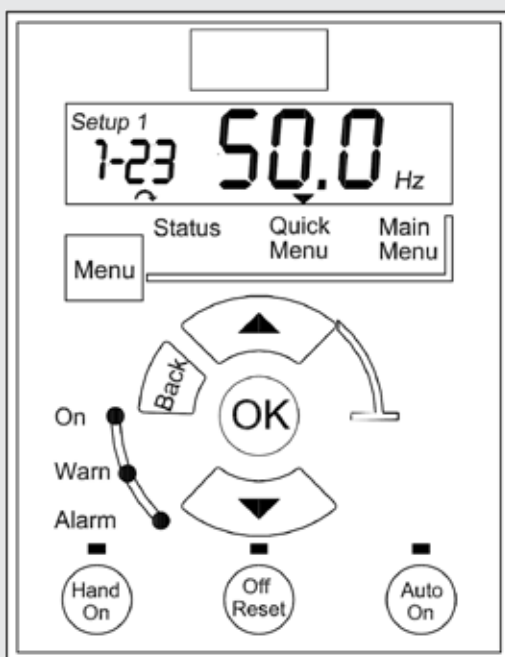

Navigation buttons:

- [Menu]: switches between quick and main menu
- [Back]: returns to the previous step
- Arrows [▲] [▼]: switches between parameter groups and sets the parameter value.
- [OK]: selects parameter and confirms changes in parameter settings

Control buttons:

[Hand on]¹⁾: starts the motor in manual mode, and enables control of the frequency inverter using the LCP control panel

[Off/Reset]: stops the motor, and resets the failures

[Auto on]: the button for automatic mode of operation – the frequency inverter is controlled either using the control terminals or serial communication.

A yellow indicator situated above the control buttons indicates the activated button (for further information, refer to FI Operating Instructions)..

REMAK parameterization presets the FI operation in Auto mode. When commissioning, it is necessary to activate this mode by pressing the [Auto on] button; during common mode of operation when controlled using the control unit or ORe5 controller, the yellow LED indicator by this button must be ON.

Motor parameters check and change procedures:

- FI must be connected to the power supply – the display backlight illuminates and the green power indicator is ON.
- Press the [Menu] button once (repeated pressing of this button cycles options QM1, QM2 and parameter set-up number „0-“).
- QM1 is displayed on the display, press [OK] to confirm.
- Using [▲] [▼], select in sequence parameter numbers 1-20, 1-24, 1-25, and check the displayed value against the value from Table # 2.
- If all parameter values correspond to the data from Table # 2 (respectively the motor rating plate), press the [Back] button once to return to the main menu.
- If the parameters do not correspond to the data from Table # 2 (respectively the motor rating plate), perform the following procedure:
 - Display parameter 1-20, and press [OK] button, the displayed parameter starts flashing, using [▲] [▼] buttons set the required value according to Table # 2, and press [OK] to confirm. Using [▲] [▼] buttons navigate to parameters 1-24 and 1-25, and repeat the same steps. Press the [Back] button twice to return to the main menu.

Warning:

As standard, REMAK delivers RF roof fans equipped with motors up to 0.75 kW output along with single-phase power supplied (1x230V) frequency inverters while their output is 3x230V as the three-phase power supply for the motor (see Table # 2); therefore, the default star connection (for standard 3x400V power network) of the motor terminals must be changed to the delta connection (see figure # 7).

¹⁾ This feature is blocked in REMAK settings

Accessory Installation

Table 2 – Frequency inverter settings

Fan type	par. 20	par. 25	Motor connection with IP21 frequency inverter (FI) – VLT® MicroDrive FC-051			Motor connection with IP54 frequency inverter (FI) VLT® HVAC BasicDrive FC-101		
	motor output	nominal motor speed	FI output	electrical connection	par. 24 motor current	FI output	electrical connection	par. 24 motor current
	(kW)	(min-1)	(kW)		(A)	(kW)		(A)
RF 56/31-4D	0,12	1360	0,37	Δ 3x 230V	0,8	0,75	Y 3x 400V	0,4
RF 56/35-4D	0,25	1380		Δ 3x 230V	1,3			0,7
RF 71/50-6D	0,37	900		Δ 3x 230V	2,2			1,3
RF 56/40-4D	0,55	1400	0,75	Δ 3x 230V	2,6			1,9
RF 71/45-4D	0,75	1400		Δ 3x 230V	3,3			2,7
RF 100/56-6D	0,55	900		Δ 3x 230V	2,9			1,2
RF 71/50-4D	1,1	1400	1,5	Y 3x 400V	2,7	1,5	4,8	
RF 100/63-6D	1,1	910			3,1		1,7	
RF 100/56-4D	2,2	1420	2,2		4,8	2,2	3,1	
RF 100/71-6D	2,2	940			4,5		4,5	

Frequency inverter setup for analogue signal control

- Default FI factory settings are configured for control by entering the commands through the digital inputs which enable connection to VCS control units or control using the ORe5 remote controller.

To enable FI connection to the control units or control using 0–10V signal, the settings of the following parameters must be changed:

- Parameter programmed set-up – parameter 0-11
- Parameter Active Set-up – parameter 0 -10

As standard, the value of these parameters is set to „1“ which must be changed to „2“ by the following procedure:

- Press the [Menu] button twice, see above.
- An arrow above the „Main Menu“ text and parameter set-up number 0-__ is displayed on the display, press [OK] to confirm.
- Using [▲] [▼] buttons, enter the number of parameter 0-10, press [OK] button, the displayed parameter starts flashing, using [▲] [▼] buttons set the value to „2“, and press [OK] to confirm.
- Using [▲] [▼] buttons, select the number of parameter 0-11, and press [OK] button, the displayed parameter starts flashing, using [▲] [▼] buttons set the value to „2“, and press [OK] to confirm.
- Press the [Back] button twice, to return to the main menu.

Upon completing the installation:

- Check the tightening of the outlet pocket screws.
- Check the motor compartment (under the upper cover) for foreign objects.
- Install the cover. Use fan washers under the screw heads!
- Properly hand over the installation

NK and NDH Roof Adaptors

NK universal roof adaptors and NDH roof adaptors equipped with attenuators serve to fit RF fans onto a roof, and they can also be used to connect a square air duct. The adaptors are terminated in a 150 mm wide base shoe (base plate) to fit and install them on the roof. The adaptors must be firmly anchored to the roof structure. Four M8 threads, spacing E x E, situated on the bottom side of the base enable the square air duct to be connected. The adaptors are made of galvanized sheet steel with waterproof sealing. Inner anti-condensate insulation is made of 20 mm thick, flame retardant polyethylene foam which is glued and mechanically secured by pins.

- NK or NDH roof adaptors make the installation of RF fans significantly easier and faster. The roof adaptors can be used on almost any type of roof. Four M8 threads, spacing A x A, situated on the top side of the adaptor enable the RF fan to be connected. Both types of adaptors in their upper part provide enough room for the VS back-flow damper.
- NDH roof adaptor has a built-in attenuator.
- Roof adaptors for applications on sloping roofs can also be ordered with their platforms adjusted to the roof slope (see figure # 17). The roof slope angle must be specified in your order.

During installation observe following instructions:

- The opening in the roof construction must not be larger than the adaptor platform and it should be of a precise square shape. The adaptor platform must be firmly anchored to the roof construction.
- Contact between the roof adaptor base and roof construction must be thoroughly sealed with sealing cement. Check the thermal resistance of the cement.
- The wiring cable can be led through the roof adaptor into the terminal box and then in the tube to the terminal box. The cable must be firmly fixed to the motor bracket and put in place just under the roof adaptor.
- Roof hydro-insulation must always be applied on the roof adaptor up to a height of 30 cm above the roof.

Accessory Installation

The end of the roof hydro-insulation must be completed with sealing cement and flashing to prevent water penetration.

- It is advisable to seal all screw joints on the fan with silicone cement.
- Standard roof adaptors (without slope) can also be connected to the air-handling duct (see figure # 15). Four M8 riveted nuts are situated in the adaptor's base plate. The dimensions of the nut pitches are shown in the figure in the introduction part.
- Before installation, paste the bottom side of the fan base and upper plate of the roof adaptor with self-sticking sealing.

To install the base, use galvanized M8 screws and nuts. It is necessary to ensure conductive connection of the flange using fan-washers placed on both sides at least on one flange connection, or use Cu conductor wiring. NK or NDH roof adaptors make the installation of RF fans significantly easier and faster. The roof adaptors can be used on almost any type of roof. Four M8 threads, spacing A x A, situated on the top side of the adaptor enable the RF fan to be mounted. Both types of adaptors in their upper part provide enough room for the VS back-flow damper.

Figure 17 – Roof adaptor on a flat roof

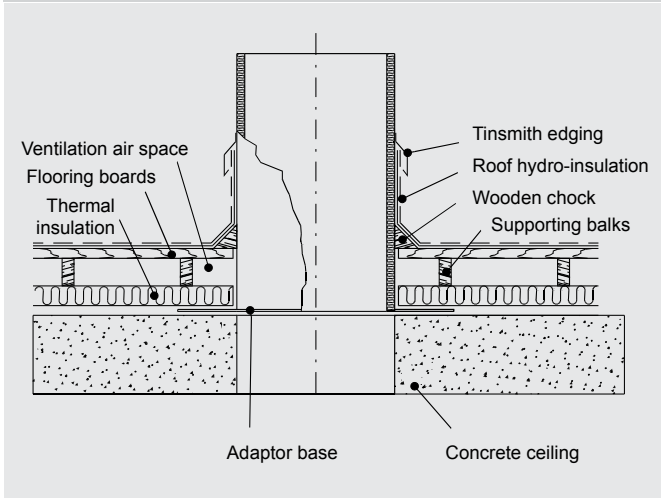

Figure 19 – Connection of the duct to the adaptor

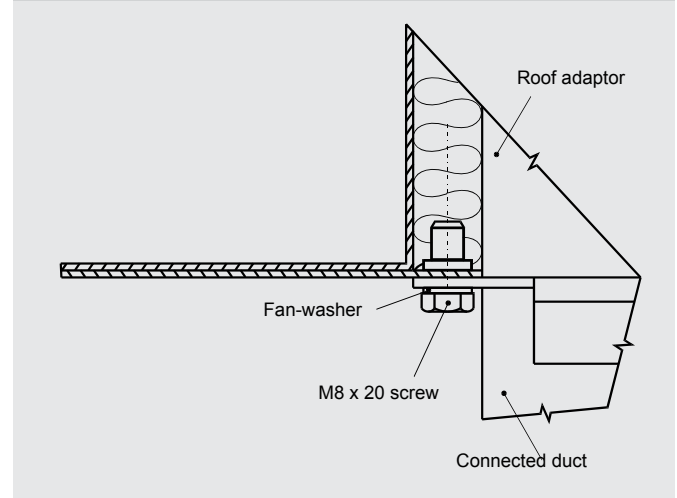

Figure 18 – Roof adaptor on a sloping roof

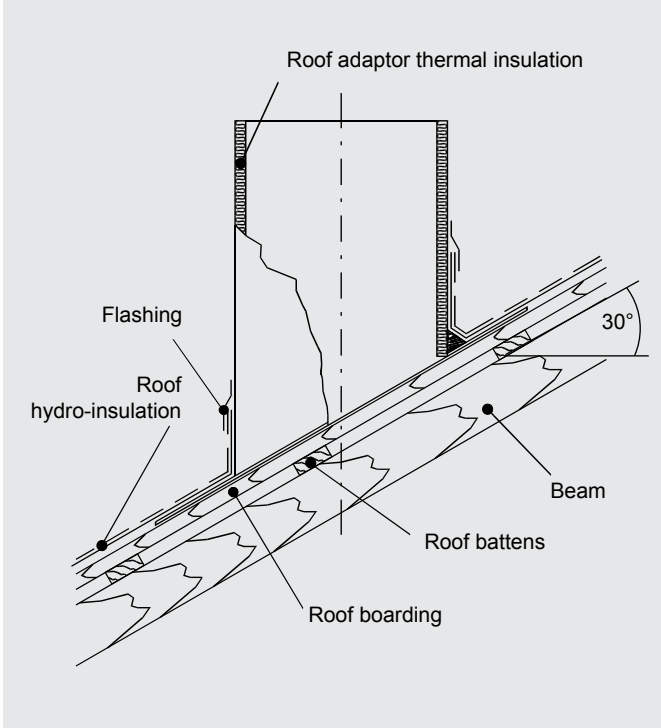

Table 3 – basic mechanical accessory

	Round low-pressure damper	Round dilatation insert	Roof adaptor	Roof adaptor with attenuator
RF	VS	DK	NK	NDH
RF 40/19-2E	VS 180	DK 180	NK 40	NDH 40
RF 40/22-2E				
RF 40/25-2E				
RF 40/28-4E	VS 250	DK 250	NK 56	NDH 56
RF 56/31-4D	VS 250	DK 250		
RF 56/31-4E	VS 315	DK 315		
RF 56/35-4D	VS 315	DK 315	NK 71	NDH 71
RF 56/35-4E	VS 355	DK 355		
RF 56/40-4D	VS 355	DK 355		
RF 71/45-4D	VS 400	DK 400	NK 71	NDH 71
RF 71/50-4D				
RF 71/50-6D				
RF 100/56-4D	VS 630	DK 630	NK 100	NDH 100
RF 100/56-6D				
RF 100/63-6D				
RF 100/71-6D				

Operating and Maintenance Instructions

Service switch

Three-pole cam switch (0-I switching) in a plastic casing with a padlock lockable control knob. Switch rated current is 16A. Switch degree of protection is IP 54. The service switch can also be installed inside the motor compartment – after removing the cover (see page 11). During installation, the ČSN EN 60204-1 ed.2 standard must be observed.

Figure 19 – Example of the service switch location

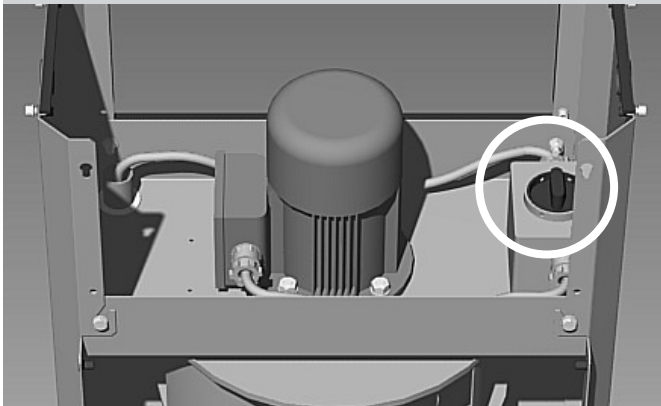

Operating and Maintenance /Service Safety Instructions

- Observe instructions from page 3.
- Maintenance may only be performed by a qualified person trained according to these Operating Instructions.
- The device can only be operated by qualified personnel.
- The service switch (delivered as an optional accessory) serves to disconnect the fan from the power supply, preventing unintentional start-up of the fan when performing maintenance. This switch does not substitute the main or emergency switches.
- The user is responsible for device use in accordance with the instructions.

Figure 20 – Service accesses

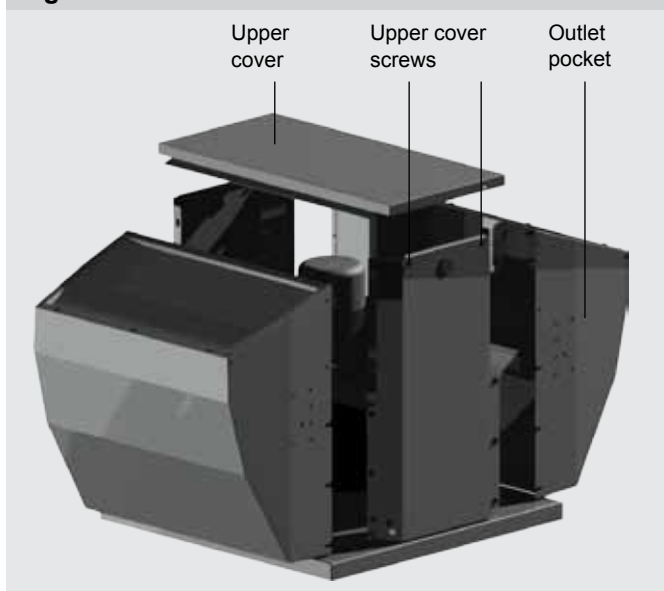

Basic Service Access

The basic service access is ensured through the upper cover. To make it easy to access the terminal box or the impeller when performing maintenance (including cleaning the dampers area of dirt – leaves, twigs, etc.), or to perform repairs, it is possible to remove the side outlet pockets.

Upper Cover Removal Procedure

Warning! There is electrical equipment under the cover! If the fan is equipped with a frequency inverter, the live electrical parts must not be touched until 5 minutes after the fan has been switched off (see warnings for frequency converter).

Warning! There is danger of cover upheaval if the fan is running! When handling the cover, avoid access to the air flow stream. Only authorized persons can remove the cover. The upper cover can be removed after removing the screws on the cover sides.

Outlet Pocket Removal Procedure

- Remove the upper cover, refer to the section above.
- Disconnect the ground conductor.
- From the motor compartment, loosen the two securing screws. Leave the fixing screws in their threads, do not remove them!
- Loosen the fixing screws (4 pcs) and securing screws (only RF71 and RF100); leave the fixing screws in their threads, remove the securing screws completely!
- Lift and tip the pocket to remove it.

Figure 21 – Outlet Pocket Removal

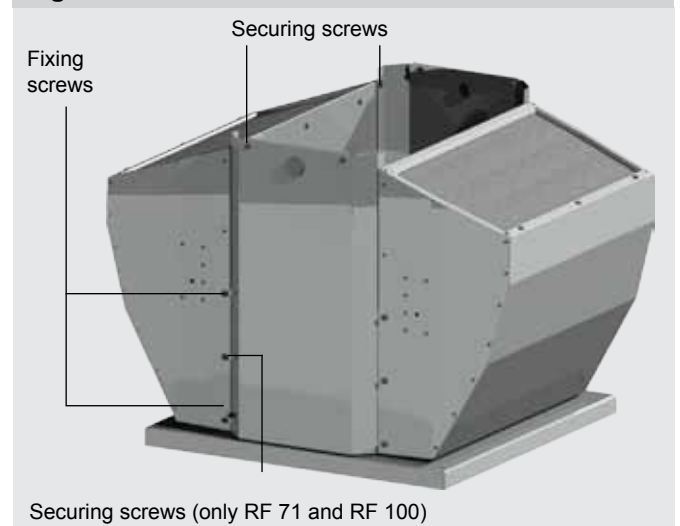

Outlet Pocket Installation procedure

- Fit on the pocket so that the screws in the upper pocket corners engage the grooves on the side plates (1).
- Push the pocket down.
- Push the pocket against the fan body so that the fixing screws (2) on the pocket side engage the U-grooves.
- Firmly tighten all screws.
- Interconnect the pockets with the ground conductor.
- Install and fix the upper cover.

Operating and Maintenance Instructions

Figure 22 – Outlet pocket installation

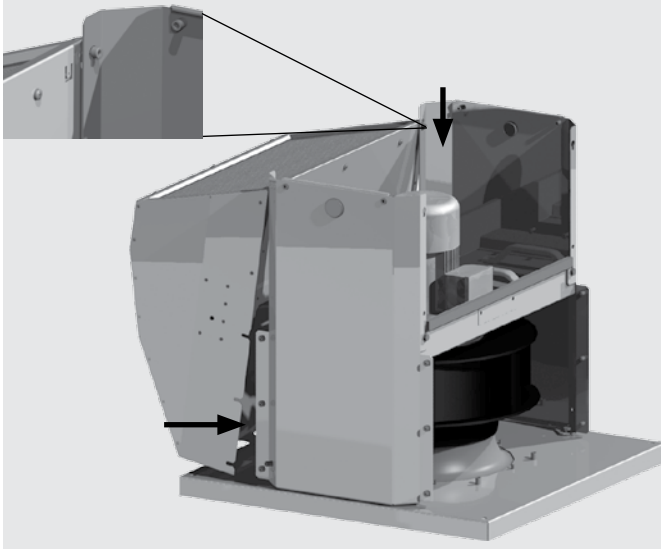

Operation and Control Description

The fan is controlled depending on the type of installed motor and the type of fan control. Fans equipped with multiple-stage speed control are switched on/off and controlled using the control panel of the ORe5, PE2,5 or PE5 controllers (depending on the fan type), or from the control panel of the TRR and/or STE(D) controller, respectively the OSX control panel. The one-stage fan is controlled in the ON/OFF mode using the STD/STE protecting relay. If the roof fan is operated in association with a parent control unit, the fan is controlled from the control panel of the control unit. Switching off the device: The fan can be switched OFF using the switch on the control panel:

- ORe5 controller: Repeatedly press the button on the face panel until the green LED indicator marked STOP goes ON. (Attention! It may be followed with a run out, if combined with a control unit.)
- PE controller: Turn the control knob on the face panel to the 0 position.
- TRRE controller: Turn the control lever to the 0 position.
- STD/STE protecting relay: Press the (0) button on the face panel.
- Control unit: Follow the instructions in the Control Unit Operating Instructions. To switch the device off permanently (take the device out of operation), disconnect it from the power supply using the circuit breaker, disconnecting the supply conductors or turning the service switch (optional accessory) to the 0 position.

Maintenance and Service Instructions

- Maintenance may only be performed by a qualified person acquainted with these Operating Instructions, and he/she must observe all applicable safety measures and regulations.
- Attention! Danger of Electric Shock! If the fan is equipped with a frequency inverter, it is necessary to wait at least 5 minutes before touching the live electrical parts (time needed to discharge the capacitor, see warning on the frequency inverter)!

- Attention! Danger of falling!
- Before starting the work, make sure the device is disconnected from the power supply. If the fan is equipped with a service switch, turn it to the 0 position.
- Always make sure unauthorized or unqualified persons not to restart the device!
- Wait until the impeller stops!
- Beware of the possible automatic fan start due to thermo-contact closing (see page 3).

Regular Inspections

Regular inspections must be performed at least once a year in the scope of the summer service inspection. If the device is operated in tough conditions, perform regular inspections twice a year, usually before and after the winter season. Perform the following checks:

- Remove the fan outlet pockets (see page 11), and perform a functionality check, including damper gravity closing. Remove any dirt.
- Clean the fan of fouling deposits.
- Check the fan casing for any looseness. Tighten the loose parts.
- Turn the impeller to check free rotation.
- Check the screwing of all wiring connections. Check the sealing.
- Perform checks following the steps on page 7 and 8.
- Check protecting coatings of all fan parts and air ducting; repair damaged painted and galvanized surfaces using suitable paint.
- Reinstall removed outlet pockets (see page 11).
- If the fan is equipped with a service switch in the motor compartment, turn it to position „I“. Properly close and fix the upper cover.
- Check the fan for proper operation; refer to the chapter „Commissioning“.

Operation Screening Checks and Service

Routine maintenance includes physical state and functionality checks and fan checks for smooth operation, noisiness (unusual noises) and tightness.

Figure 23 – Power unit removal

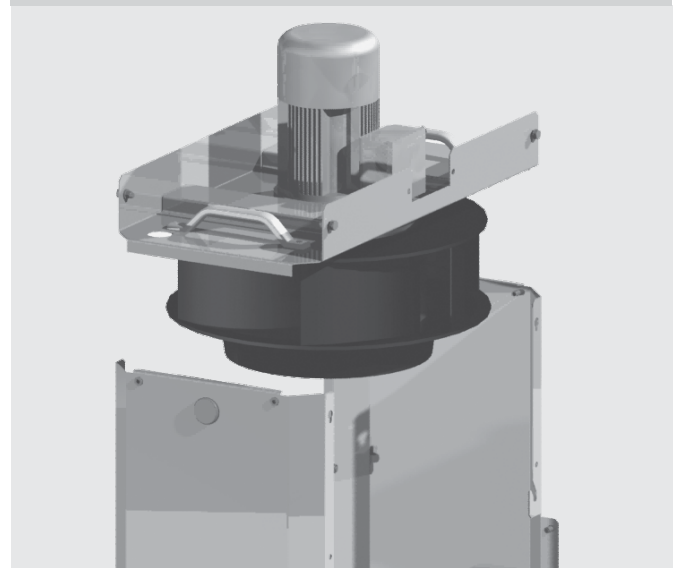

Operating and Maintenance Instructions

Fan Power Unit Replacement

Power unit removal from the fan casing

- Disconnect the fan from the power supply, and secure it against accidental start; wait until the fan stops.
- Remove the fan cover (see page 14).
- Loosen the bolts on both sides of the motor bracket. Remove the bolts with nuts. Loosen the guiding screws but do not remove them!
- Lift the bracket including power unit up from the fan casing. Attention! The assemblies of heavy air handling units can be as heavy as 55 kg.

Impeller removal from the motor shaft

Single-phase motors and impellers create a compact aggregate. Three-phase fans are equipped with IEC motors, and the impeller is fitted on the motor shaft. The RF100/xx fan impeller is fixed to the shaft using a TaperLock® hub.

Impeller removal from the feathered shaft

- Turn the power unit with the impeller up.
- Remove the securing screw with washer.
- Install at least 80 mm long M6 screws in both holes inside the impeller hub.
- When screwed in, the screws will seat on the motor flange.
- Alternatively, screw in the screws to push out the impeller from the shaft.

Impeller removal from a shaft with a TaperLock® hub

- Turn the power unit with the impeller up.
- Remove the securing screw with washer.
- Remove the fastening screws from the hub, and insert one of them into the force-off hole.
- Keep tightening the screws until the clamp bushing is released from the impeller hub.

After installation, it is recommended to balance the assembly. An unbalanced assembly can cause vibrations which are transferred to the building structure and reduce the device's service life.

Figure 24 – Impeller and TaperLock® hub fitting

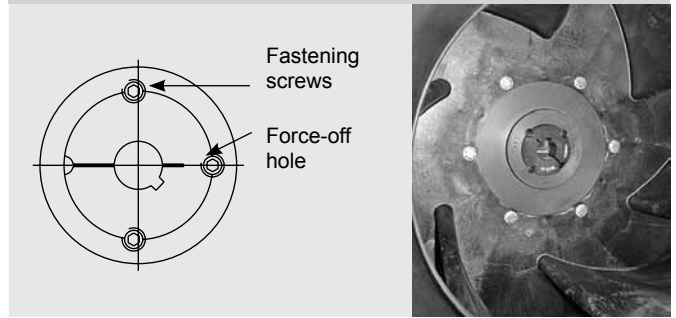
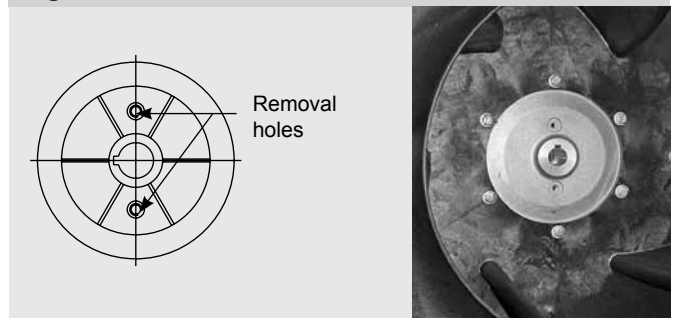

Figure 25 – Removal from the feathered shaft



Disposal

When using or disposing of the air-handling unit, it is necessary to observe the respective national environmental protection and waste disposal regulations. In case of final liquidation of the device, it is necessary to follow the policy of sorted waste disposal; this means to respect differences in materials and their composition (see table). It is necessary to hire a provider specialized in sorted waste disposal in accordance with applicable local standards and regulations.

After exceeding its service life limit, the unit belongs to waste group Q14 according to the Waste Act (No.185/2001 Sb.).

Table 4 – used materials

Material	Component	
Aluminium alloy	Fan base, supporting side plate, outlet pocket parts, upper cover and RF100/71-6D impeller	
Galvanized steel	Motor bracket	
Steel coated with protective coating	Fan base, RF 56/40-4E impeller	
Plastic	PE	Grommets
	PVC	terminal box, service switch casing
	PPO	Wiring cable tube
	pryž	Blinding plugs, neoprene nuts
Copper	Conductors	
Multi material elements	Motor, capacitor	
Plastic + steel	Impeller (except RF100/71-6D and RF 56/40-4E), terminals	
Materials used to pack the product:		
Cardboard	Cardboard box	
Polyethylene	Packaging foil	
Wood	Pallet, crating	

Troubleshooting

Spare Parts and Service

Warranty and regular servicing can be ordered from REMAK a.s. or the regional distributor. The manufacturer can authorize trained service providers to perform this service; The list can be found at www.remak.eu

Troubleshooting

The table below includes possible causes of problems and their removal. If the problem cannot be removed by an authorized technician, contact our Customer Service Department.

Table 5 – Possible problems and their removal

Problem symptom	Possible cause	Solution
The fan impeller does not turn	Disconnected power supply	Check the circuit breakers
	Activated motor thermal protection *)	- Fans without brought-out protection – wait until the motor cools down
		- Fans without brought-out thermal protection – switch the fan off and on (reset)
		- If the fan is protected by the control unit – perform failure unblocking
The service switch (optional accessory situated inside the fan) is turned to the OFF position	Turn the service switch to the ON position	
	Damaged motor	Measure the motor winding resistance
Thermal protection is being repeatedly activated	Too high temperature of transported air	Check the transported air temperature and max permissible temperatures for the given fan type (refer to the designer's catalogue „Duct units Vento“).
	Power unit seizing	Check the power unit for free rotation of the impeller, motor or motor winding damage
	Frequent switching of the motor	Avoid frequent motor switching
	Direction of rotation reversed	Check the proper direction of rotation (see page 10)
High fan vibration	Imbalanced assembly	- Check the impeller for damage
		- The assembly must be balanced
The fan impeller is catching	The assembly is offset	- Check the evenness between the roof adaptor and fan base; check the fan base for straining and distortion. - Loosen and properly refit the outlet pockets. - Outlet pockets influence the fan wind bracing
	The motor bracket supporting the power unit is not properly fitted	Loosen the motor bracket bolts, fit it properly and tighten the bolts
Insufficient fan output	The impeller's direction of rotation is reversed	Check the proper direction of rotation (see page 10)
	Fouled or damaged closing dampers	Check the functionality of the dampers
	Restricted or damaged outlet air ducting	- Check the outlet air ducting. - Undersized fan, it does not comply with the proper design requirements, e.g. the outlet air ducting pressure loss
Malfunction indicator on the controller signals a failure	The fan thermal protection has been activated (see above), and the fan disconnected	- Turn the switch on the control panel to the STOP position (respectively, repeatedly press the button on the Ore controller) to reset the fan. - Reset the frequency inverter (if included). - If the problem persists, follow the steps above
Water drops from the fan	Insufficient air-handling assembly thermal insulation	Inspect the thermal insulation of the entire system; if needed, insulate unprotected surfaces
	Free air flow can cause condensate to form on the cool parts of the fan	Insert the vacuum damper into the air-handling system to prevent free air flow
	Leakage, improper installation	Check the roof assembly water-tightness, gap sealing in the low pressure area, including diffuser, adaptor, hole and screw connections in the fan base
	The dampers are stuck in the open position	- Clean the interior of the dampers. - Adjust the damper turning mechanism. - Check the fan sloping angle (see page 5).

*) We recommend checking the fan immediately and finding the cause of the failure, especially if the failure persists.



Notes

Printing and language mistakes are reserved.

These Installation and Operating Instructions (as a whole or a part) must not be printed or copied without prior written permission from REMAK a. s., Zuberská 2601, Rožnov pod Radhoštěm. These Installation and Operating Instructions are the sole property of REMAK a. s.

Changes reserved.

Issued: 26th August 2013



REMAK a.s.
Zuberská 2601, 756 61 Rožnov pod Radhoštěm,
tel.: +420 571 877 878, fax: +420 571 877 877,
email: remak@remak.eu, internet: www.remak.eu