



GEOVENT

INSTRUCTION MANUAL



GRTU 3800+

Roof Top Unit

Contents

1.0 Field of application	2
1.1 Function	2
2.0 Technical data	2
2.1 Efficiency	2
2.2 Pressure drop	2
2.3 Noise emission	3
2.4 Construction	3
2.5 Dimensions	3
2.6 Construction, automatic	4
3.0 Installation	5
3.1 Electrical wiring	6
3.2 Automatic	6
3.3 Daily use	6
3.4 User menus	6
4.0 Responsibility	7
5.0 Error messages - motor	8
6.0 EC declaration of conformity according to IIA	10
Appendix	11

1.0 Field of application

Geovent GRTU 3800+ Roof Top mounted Unit is a ventilation unit with rotor heat exchanger and EU7 filter used for comfort ventilation of industrial premises, auto repair shops, arenas, etc.

GRTU 3800+ is recommended for use with a piping system and inlet bags for maximum efficiency, but can also be used with a diffusor for mixing.

1.1 Function

Geovent GRTU 3800+ is built around a rotary heat exchanger that recovers up to 84% of the heat in the extracted air.

The hot exhaust air is extracted through the EU7 filter and emits the heat to the rotor exchanger before it is ejected out the left side of the unit (seen from the front). Fresh outdoor air is taken into the unit on the opposite side, filtered through the EU7 filter and absorbs the heat from the rotor exchanger before it is blown into the room.

2.0 Technical data

Item no. 02-602A:
 GRTU 3800+
 3x400V, 50 Hz, 8,0 A
 Ventilators: 2x1500 W .
 Capacity - up to 4.500 m³/h
 k-factor 121

Weight: 400 kg

Filter size: 565x1137x24
 Cassette filter EU7

2.1 Efficiency

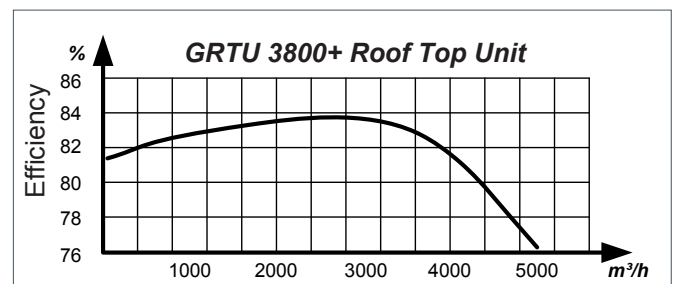

2.2 Pressure drop

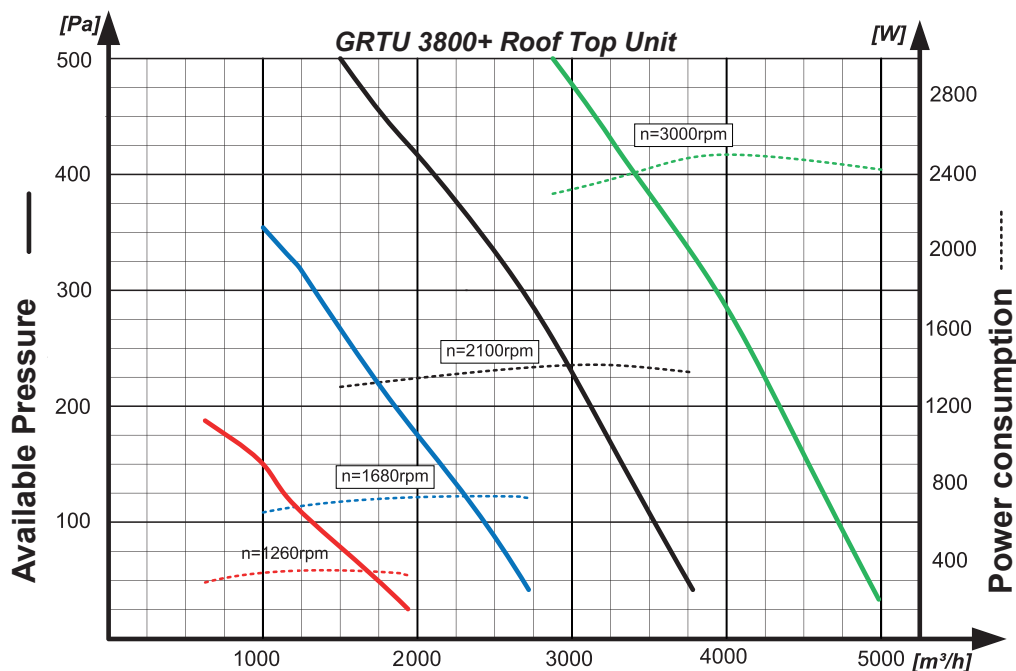

2.3 Noise emission

Sound pressure from fans at 2100 rpm. The unit's own noise reduction is not included.

Sound level Hz	63	125	250	500	1K	2K	4K	8K	Total
Intake	45	57	66	67	63	61	58	58	72
Exhaust	43	55	64	64	61	59	56	56	70

Sound to the surroundings measured by intake:
GRTU 3800+: 75 dB(A)

2.4 Construction

Cabinet: Galvanized plate inside and outside with 50 mm insulation.

Module construction with rail system facilitates inspection/replacement of parts.

The entire construction is galvanized and sealed in joints.

Fans:
1,4 kW EC motors, Ziehl-Abegg

Rotor: Hoval

Automatic/control: OJ Air2

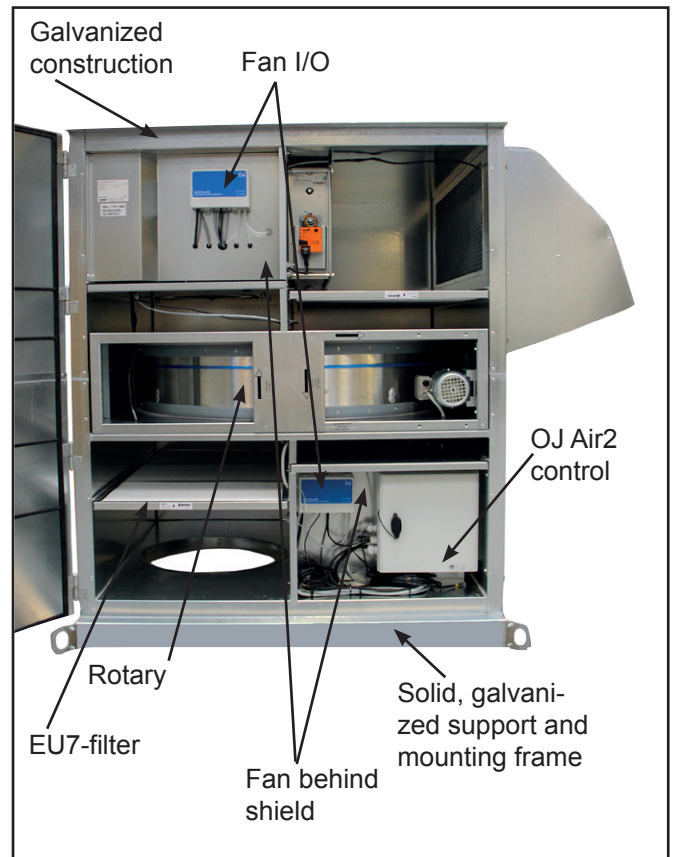
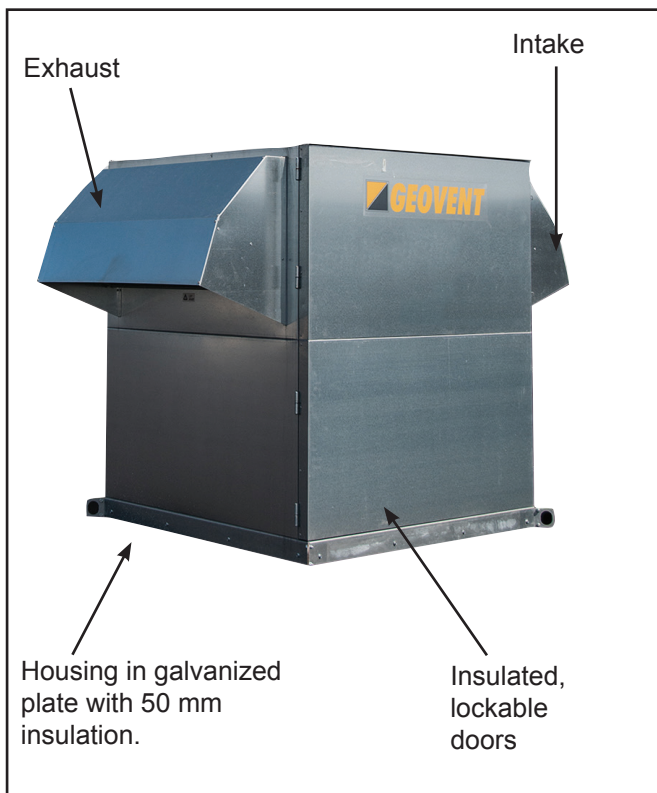

2.5 Dimensions

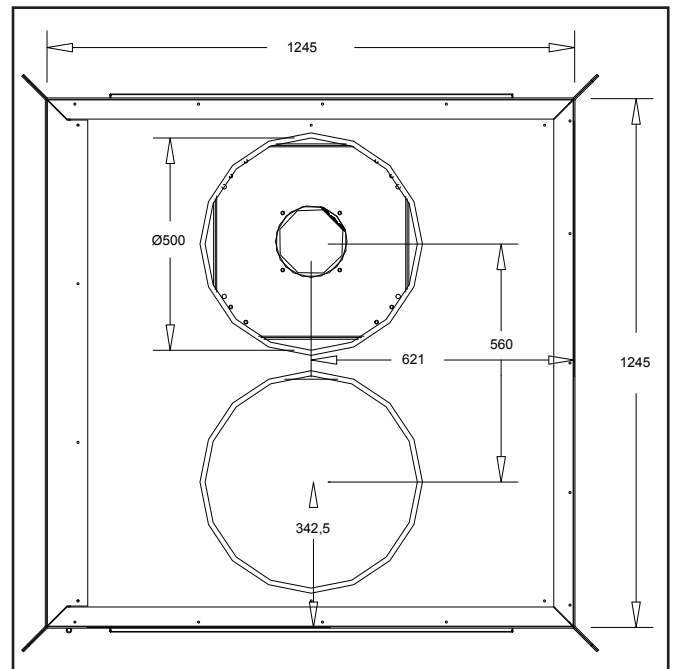

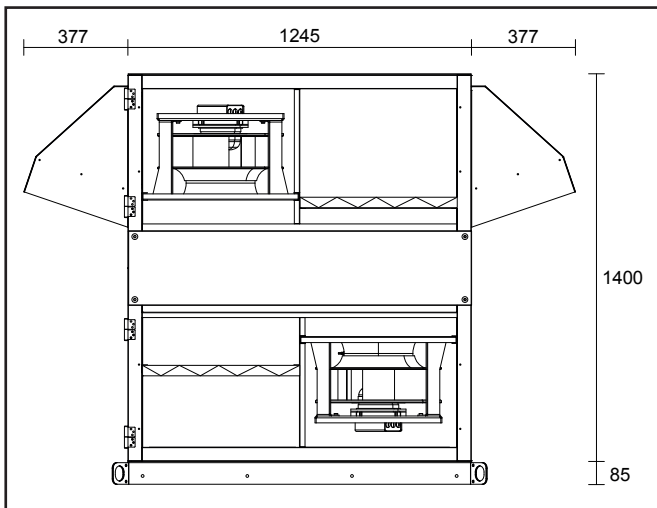

2.6 Construction, with automatics

The following shows the structure of the GRTU 3800+ with position of sensors and automatic control in standard version.

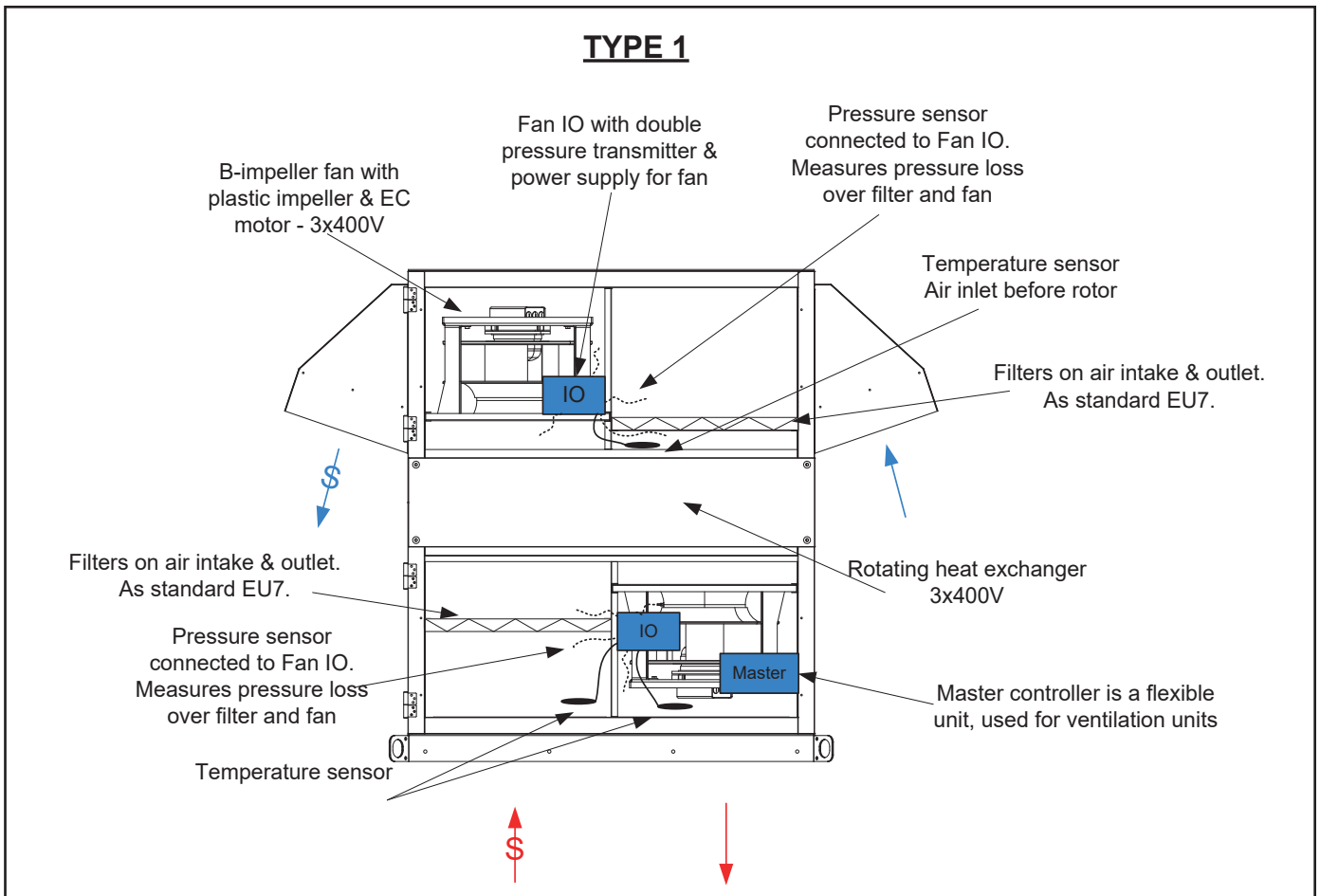

3.0 Installation

The GRTU Roof Top Unit can be mounted on both flat and sloped roof.

For both roof types, proper roof support must be used. In the case of sloped roof, it is recommended that the inspection side is towards the sloping side.

Construction dimensions for roof structure (outside dimensions):

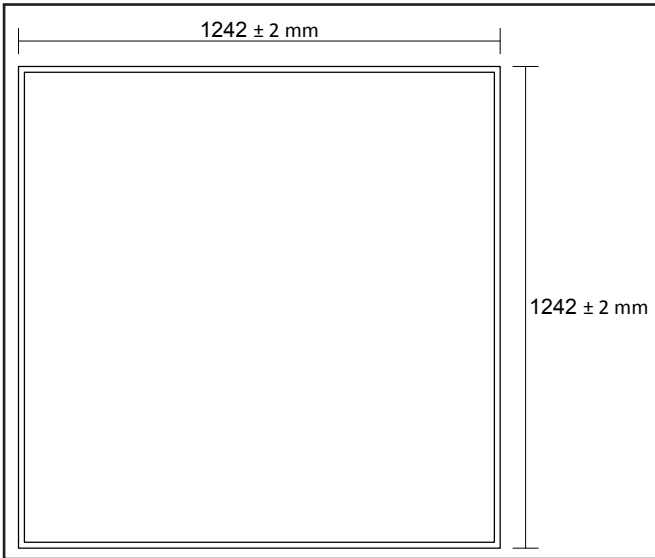

Example of roof structure

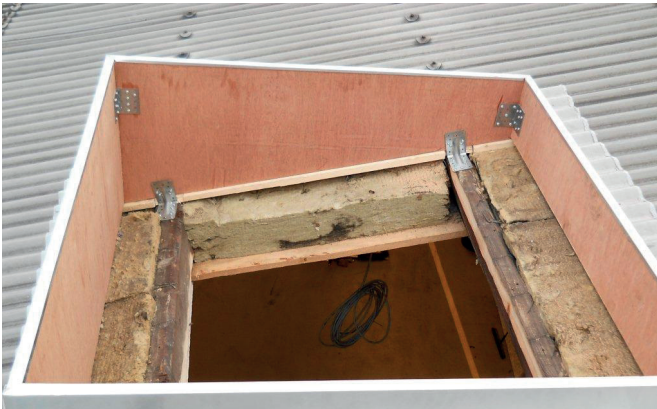

Roof mounting

For directly mounted diffuser solution, the hole in the roof must be $1160 \times 820 \text{ mm}$.

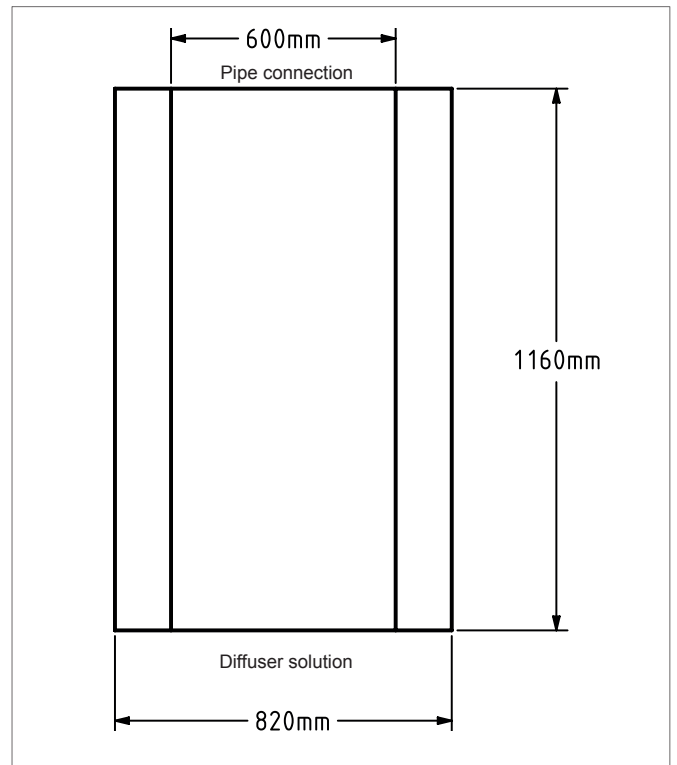

GRTU 3800+ can also be installed indoors, duct connection for intake and discharge will be at the top of the unit. Please state when ordering.

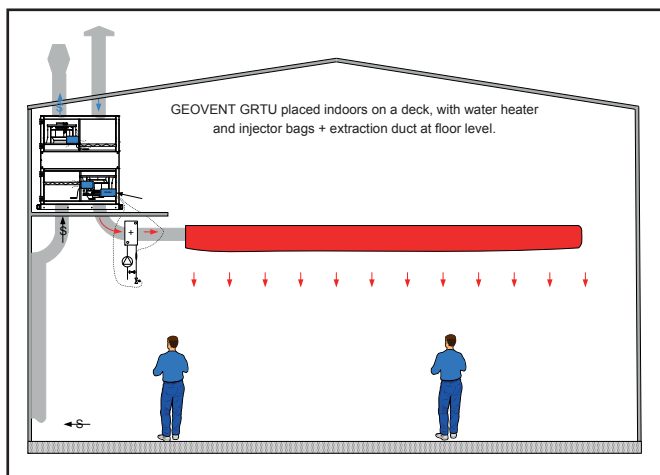

Design for duct installation

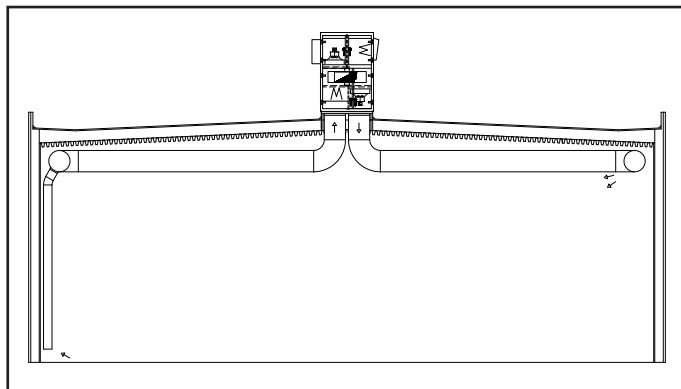

3.1 Electrical wiring

Wiring for supply voltage (3x400) and wiring for remote control can be routed externally (through the side of the unit) or inside the inlet duct. Typically, the cables are placed in the duct.

3.2 Automatic

The automatic is OJ Air2 control and consists of: Master controller, filter guard (Fan IO) and hand terminal. Everything is internally wired and ready for use, however, sensors and hand terminal outside the unit must be mounted.

The controller maintains the set air volume and continuously regulates the fans. Shows alarm in case of malfunction and filter change. Can handle recirculation and heating coil.

Day and week setting allow for personal adjustments.

The automation is set by the technician for the current installation. See separate technician instructions.

NB: During installation, a filter measurement must be performed by the technician.

Hand terminal



3.3 Daily use

The daily operation of the GRTU 3800+ takes place via the handheld terminal, which is operated by the Touch screen, see subsequent menus.

Alarms from the system are displayed on the display.

3.4 User menus

The following menus show the parameters available to the daily user.

3.4.1 Fan operation

Setting the operational program for the unit:

Stop: The unit is stopped. The automatic remains active and the unit can be started by changing the operating program.

Low: The unit runs at constant low airflow. The desired amount of air is kept constant by regulating the fan speed. By default, the air volume is set to 1.500 m³/h.

High: The unit runs at constant high airflow. The desired amount of air is kept constant by regulating the fan speed. By default, the air volume is 4.500 m³/h.

Weekly

program: The unit has 3 weekly programs for adjusting operating variations. See below.

3.4.2 Weekly Program

Selecting and setting the weekly program. 4 timers can be set per point/image in the menu. Settings for Stop, Low or High. See above.

The weekly program is overridden by extended operation.

1. The entire week: A time schedule that applies for all 7 days of the week.
2. Weekdays and weekends: two settings for weekdays and weekends respectively.
3. Daily program: Setting up the time program for each day of the week.

3.4.3 Temperature

Setting the supply air temperature. Only used when heating coil is installed.

3.4.4 Alarms

Alarms are shown in the display of the hand terminal. The unit will turn of the alarm when the cause is corrected.

If the filter is replaced during service, you must perform a filter measurement.

Some alarms must be reset manually when the cause is corrected. See appendix for alarms.

4.0 Responsibility

Warranty

Geovent A/S will provide warranty on products that are subject to faults or defects that are proven to be due to poor processing or materials by Geovent. The warranty covers damages (repair or replacement) until one year after the date of dispatch. Claims cannot be raised against Geovent A/S for lost earnings or operating losses as a result of faults in Geovent's products.

Worn parts such as wheels and hoses are not covered by the warranty.

User responsibility.

For Geovent to provide the stated warranty, the user/ technician must have followed this instruction manual in all respects.

No modifications or structural changes must be made to the slide channel and its function. Geovent's liability lapses as a result of modifications.

Please also refer to the applicable Terms and Conditions at www.geovent.dk.

5.0 Error messages - motor

Errors are indicated by sequences of flashes from lights on the motor cover, which has a different meaning depending on the number of flashes.



OFF	_____
ON	████████████████████
1 x	██ ██ ██ ██ ██
2 x	███ ███ ███ ███ ███
3 x	█████ █████ █████ █████ █████
4 x	██████ ██████ ██████ ██████ ██████
5 x	████████ ████████ ████████ ████████ ████████
6 x	█████████ █████████ █████████ █████████ █████████
7 x	██████████ ██████████ ██████████ ██████████ ██████████
8 x	███████████ ███████████ ███████████ ███████████ ███████████
9 x	█████████████ █████████████ █████████████ █████████████ █████████████

See explanation next page.

Error messages - explanation

Code	Reason / explanation	Motor response
Off	No input voltage	Can voltage be measured?
		Explanation: The device automatically disconnects and connects when voltage is available.
On	Normal operation	
1 X blinks	No enable =OFF No connection between "D1" - "24V" Missing start signal..	No start signal from Fan IO
2 X blinks	Reduced operation. The unit is equipped with temperature sensor that protects against high temperatures. To avoid a breakdown, the unit runs at reduced strength.	When the temperature reaches a safe level, the operation resumes.
		NB: Ensure that the motor is sufficiently cooled.
3 X blinks	Error in signal from HALL sensor	The control switches off the motor. Automatic restart if the cause of the error is corrected.
4 X blinks	Line error (only for 3 phase motors) This unit is equipped with a phase monitoring function. In case of low voltage/no voltage at one or more phases, the device is interrupted after a short delay - Approx. 60ms.	After a power failure, a restart will be attempted 15 seconds later, if the voltage is high enough. This happens until all 3 phases are operating. Examine the power supply.
5 X blinks	Motor blocked. If the motor is not turning the following error is reported: Motor blocked.	The motor switches off and tries to restart after approx. 2.5 sec. After four attempts, a reset is required or that you disconnect the power and switch it back on again.
		Solution: It must be ensured that the motor rotates freely.
6 X blinks	Short circuit on earthing or motor windings.	The motor switches off and tries to restart after approx. 60 sec. The motor will disconnect if the error persists. After that a reset is required or that you disconnect the power and switch it back on again.
		Solution: Check that ground connections are set up correctly.
7 X blinks	Too low DC voltage If a voltage drop is detected the motor stops.	If the voltage increases again within 75 sec. an automatic start test is carried out. If the motor does not start, a reset is required or that you disconnect the power and switch it back on again.
8 X blinks	Too high DC voltage. The motor is switched off.	If the voltage drops again within 75 sec. an automatic start test is carried out. After that a reset is required or that you disconnect the power and switch it back on again.
9 X blinks	IGBT overheating. Cooling - 60 sec - attempt twice. Then Error 6.	

6.0 EC declaration of conformity according to Appendix IIA



GEOVENT

HOVEDGADEN 86 • DK-8831 LØGSTRUP
(+45) 8664 2211 • salg@geovent.dk

Manufacturer hereby declares that:

Product: Roof Top Unit
Model: GRTU 3800+

complies with the following directives and standards:

Directive 2006/42/EC of the European Parliament and the Council of 17 May 2006 regarding machinery and amendments to Directive 95/16/EC

EN ISO 14121-1:2007 Risk Assessment - Part 1

EN ISO 12100-1:2005 Basic concepts and general principles of design

EN ISO 12100-1:2009 design and shaping
Part 1: Basic terminology and methodology

EN ISO 12100-2:2005 Basic concepts and general principles of design

EN ISO 12100-2:2009 design and shaping
Part 2: Technical principles

Authorized to compile the technical file:

Lise Cramer

Date: 08.08.2023

Position: Managing Director
Name: Thomas Molsen

Signature:

Appendix

Alarm No:	Alarm text	Alarm type	Auto reset	Aggregat stop	Troubleshooting
1	Fire alarm	A			Digital input "Fire alarm" open.
2	External fire thermostat alarm	A		*	Digital input "External fire thermostat" open.
3	Internal fire alarm	A		*	Supply air / exhaust air temperature values is above the specified limits.
4	External stop	B	*		Digital input "External stop" open.
9	Filter monitor flow compensation not calibrated	B	*		Pressure reference for filter not completed. Alarm shown after 20 min.
10	Handset: No communication	B	*		Handterminal not connected, bus cable failure.
11	FanIO 1: no communication	A	*	*	FanIO not connected to bus in FanIO socket A, Error in bus cable, FanIO DIP switch position is wrong
12	FanIO 2: no communication.	A	*	*	FanIO not connected to bus in FanIO socket A, Error in bus cable, FanIO DIP switch position is wrong
20	Temperature sensor fault: Supply	B	*		Supply sensor disconnected/short-circuited, Sensor not configured for a temperature input
21	Temperature sensor fault: Extract	B	*		Extract sensor disconnected/short-circuited, Sensor not configured for a temperature input
22	Temperature sensor fault: Room	B	*		Room sensor disconnected/short-circuited, Sensor not configured for a temperature input
23	Temperature sensor fault: Exhaust	B	*		Exhaust sensor disconnected/short-circuited, Sensor not configured for a temperature input
24	Temperature sensor fault: Outside	B	*		Outside sensor disconnected/short-circuited, Sensor not configured for a temperature input
25	Temperature sensor fault: Return water	A	*	*	Return water sensor disconnected/short-circuited, Sensor not configured for a temperature input
26	Temperature sensor fault: Heat recovery	B	*		Heat recovery sensor disconnected/short-circuited, Sensor not configured for a temperature input
27	Pump alarm, heating	B	*		Digital input "Heating battery error" open, Alarm from circulation pump.
28	Frost alarm, water Heater	A		*	Low water temperature, circulation pump malfunction, low outdoor temperature
30	Inlet frequency conv.: Low supply voltage (Vlo)	B			Low supply voltage
31	Inlet frequency conv.: High supply voltage (Vhi)	B			High supply voltage
32	Inlet frequency conv.: High output current (Ihi)	B			Motor or cable shortcircuit, Motor blocked, Wrong motor type
33	Inlet frequency conv.: High temperature (Thi)	B			High ambient temperature, frequency converter overload.
34	Inlet frequency conv.: Lacking supply phase	B			Supply voltage is missing a phase
35	Inlet frequency conv.: High internal ripple voltage	B			Supply voltage unstable, Frequency converter overload
37	Frequency converter alarm, Supply	B			Digital input " Frequency converter alarm, Supply " open
38	Filter, Supply	B			Supply filter pressure drop to high, dirty filter
39	FanIO 1: +24V DC overloaded	A		*	24V DC from FanIO 1 terminal 14,16,18 short circuit, consumption from FanIO 1 is greater than 0,6A.
41	Exhaust frequency conv.: High supply voltage (Vhi)	B			High supply voltage, braking time is to short
42	Exhaust frequency conv.: High output current (Ihi)	B			Motor or cable shortcircuit, Motor blocked, Wrong motor type
43	Exhaust frequency conv.: High internal temperature	B			High ambient temperature, frequency converter overload.
44	Exhaust frequency conv.: Lacking supply phase	B			Supply voltage is missing a phase
45	Exhaust frequency conv.: High internal ripple voltage	B			Supply voltage unstable, Frequency converter overload
47	Frequency converter alarm extract	B			Digital input " Frequency converter alarm, Extract " open
48	Filter, extract	B			Extract filter pressure drop to high, dirty filter

49	FanIO 2: +24V DC overloaded	A	*	24V DC from FanIO 2 terminal 14,16,18 short circuit, consumption from FanIO 2 is greater than 0,6A.
58	Frost alarm, heat exchanger	B		Exhaust temperature below frost limit, although By-pass damper is fully open.
60	Low supply temperature	B		Supply temperature has been 5 C° too low for more than 10 minutes. Not enough heat available, low outside temperature.
61	High inlet temperature	B		Supply temperature has been 5 C° too high for more than 10 minutes. Not enough cooling available, high outside temperature.
62	Low extract temperature	B		Extract temperature has been 5 C° too low for more than 20 minutes. Max supply temperature too low, airvolume too low.
63	High extract temperature	B		Extract temperature has been 5 C° too high for more than 20 minutes. Max supply temperature too high, airvolume too low.
65	Heating cut out due to low air volume	B	*	Output too heating coil reduced.
66	Electric battery: overheating alarm	B		Heating coil overheated.
70	High CO2	B	*	CO2 level too high for more than 20 minutes. Min. Supply temperature too high. airvolume too low.
71	Low supply air volume	B		Supply air volume 10% too low for more than 10 minutes.
72	High supply air volume	B		Supply air volume 10% too high for more than 10 minutes.
73	Low extract air volume	B		Extract air volume 10% too low for more than 10 minutes.
74	High extract air volume	B		Extract air volume 10% too high for more than 10 minutes.
75	Low inlet air pressure	B		Supply pressure 10% too low for more than 10 minutes.
76	High inlet air pressure	B		Supply pressure 10% too high for more than 10 minutes.
77	Low exhaust air pressure	B		Extract pressure 10% too low for more than 10 minutes.
78	High exhaust air pressure	B		Extract pressure 10% too high for more than 10 minutes.



GEOVENT

HOVEDGADEN 86 • DK-8831 LØGSTRUP
(+45) 8664 2211 • salg@geovent.dk