

ProNordic L110R

ART.NO. 151000

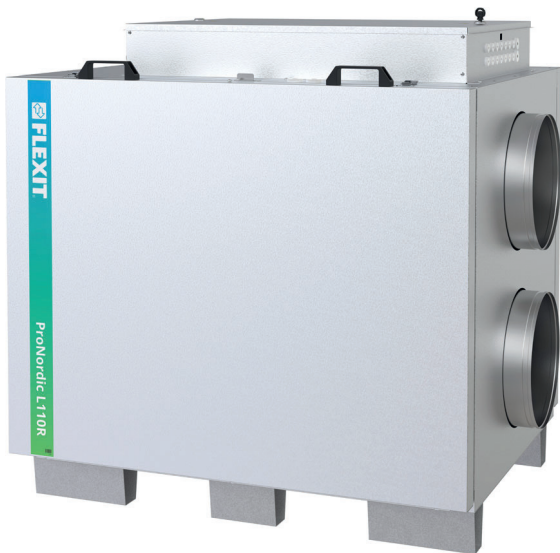

Air handling units with rotary heat exchanger for commercial buildings.

Nominal air volume 1 300 m³/h against 200 Pa.

Product features

- Units kept on stock at Flexit
- Flexible - impossible to order wrong variant
- Energy efficient and silent
- Easy control by Siemens Climatix

Automatic control

Choose between ProPanel and ProTouch control panel.



ProPanel



ProTouch

Description

Flexit ProNordic L110R is air handling units for commercial buildings kept on stock at Flexit.

Supplied as a right hand variant, but can be easily rebuilt on site to the left hand variant.

The after-heating battery (electric/water) is supplied with the units and installed on site.

The unit's compact physical dimensions simplifies transport and make the products flexible and adaptable to most installations.

The flexibility gives cost savings in the event of changes in projects and makes it impossible to order wrong variant.

The units can also be ordered pre-configured as desired, but with a certain delivery time.

Easy control with Siemens Climatix by control panel ProPanel or ProTouch.

Art.no.	GTIN	Model
151000	7023671510008	ProNordic L110R

	η	SFP	Duct resistance	Airflow
PERFORMANCE	> 84 %	< 2.0	200 Pa	1 300 m ³ /h
	> 86 %	< 1.5	200 Pa	1 000 m ³ /h

		L110R with electric battery	L110R with water battery
POWER	Rated voltage (AC 50 Hz)	3N~400 V	3N~400 V
	Frequency	50 Hz	50 Hz
	Fuse size	3 x 16 A	3 x 10 A
	Rated current	10 A	3,1 A
	Rated power, total	6 010 W	1 210 W
	Rated power, max. electric battery	4 800 W	-
	Rated power, fans	2 x 500 W (230 V)	2 x 500 W (230 V)
	Rated power, rotor motor	40 W	40 W

VENTILATION			
	Fan type	B-wheel	B-wheel
	Fan motor control	ModBus	ModBus
	Max. fan speed RPM	3 000	3 000
	Automatic control, standard	CS 2500	CS 2500
	Filter class	ePM1 55% (F7)	ePM1 55% (F7)
	Filter type (supply air/extract air)	Compact filter	Compact filter

DIMENSIONS	Filter dimensions (W x H x D)	795 x 380 x 85 mm	795 x 380 x 85 mm
	Gross unit weight	181 kg	181 kg
	Net unit weight inward transport	87,5 kg	87,5 kg
	Weight, fan	2 x 9 kg	2 x 9 kg
	Weight, rotor	43,5 kg	43,5 kg
	Weight, doors	2 x 16 kg	2 x 16 kg
	Duct connection	Ø315 mm	Ø315 mm
	Height	1 130 mm	1 130 mm
	Width	1 230 mm	1 230 mm
	Depth (with håndtage)	910 mm	910 mm
	Depth (without doors)	795 mm	795 mm

Dimensioned drawings

Dimensions in mm

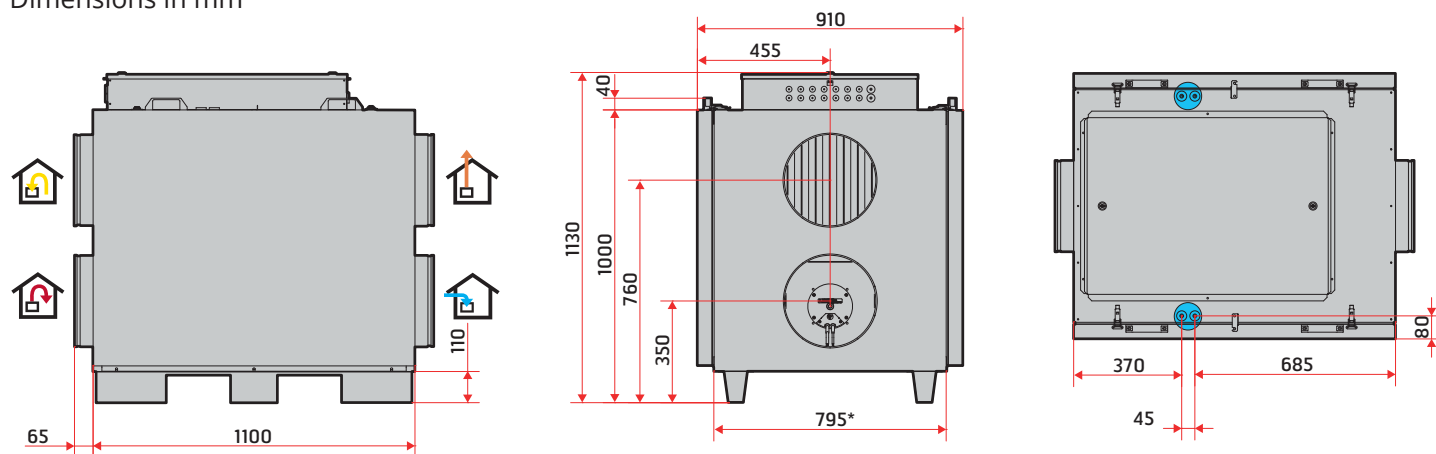

*without door

The dimensions are the same on both end sides.

 water connection points

Capacity diagram

Supply air side

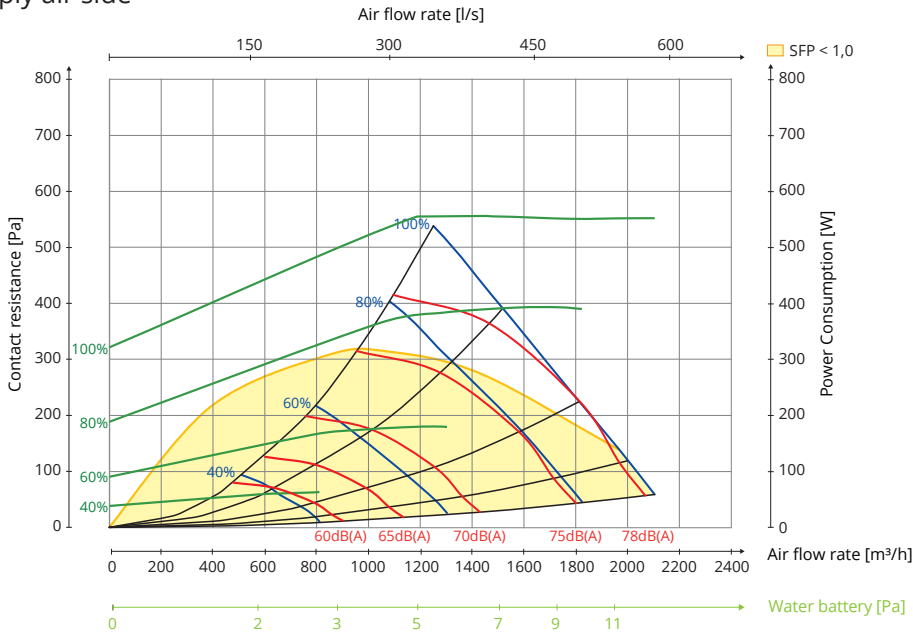

Extract air side

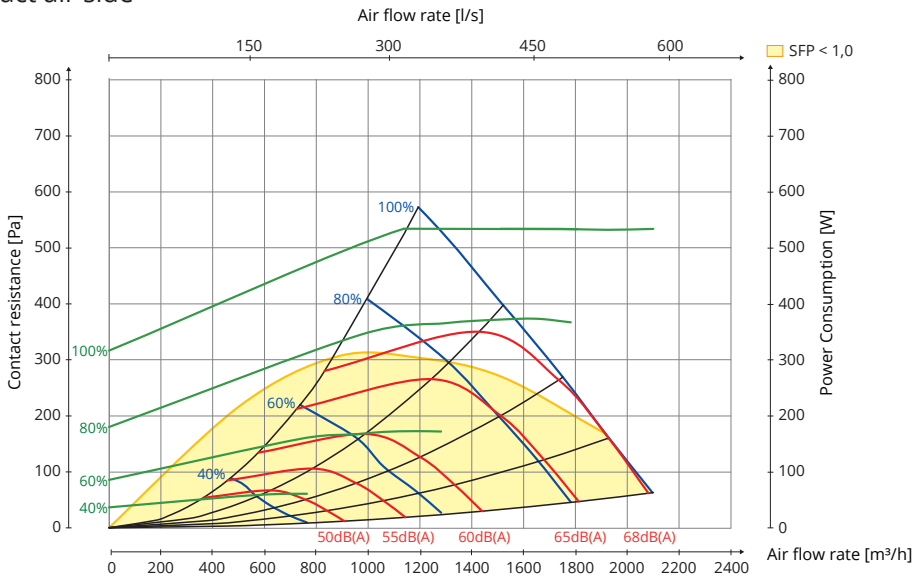

Hz	63 Lw(dB)	125 Lw(dB)	250 Lw(dB)	500 Lw(dB)	1000 Lw(dB)	2000 Lw(dB)	4000 Lw(dB)	8000 Lw(dB)	LwA (dBA)
Supply air	5	5	-4	-5	-4	-8	-17	-15	
Extract air	8	8	1	-4	-9	-15	-21	-25	
Radiated sound	-36	-27	-20	-28	-31	-31	-33	-43	-22

For control and calculation of SFT_{INT} and SFP_{Limit} use FlexitSelect.

Explanation of diagram:

Sound data is specified as sound power level LwA in the capacity diagrams. (This is sound to duct.)

These values can be corrected by means of the table for the different octave bands in order to look at Lw (without adaptation to A band).

The correction table for the various octaves is stated in Lw, which means that the Lw values are after conversion of each octave for supply air and extract air.

Radiated sound from the unit must be calculated from the supply air diagram.

Unit	
151000	Air handling unit L110R



Tarvikkeet, Ilmanvaihtokone

112672	Control panel, ProPanel
118257	Control panel, ProTouch
110624	Filter set F7
14477	Closing air damper Ø 315mm on/off
14478	Closing air damper Ø 315mm spring
118139	Electric heating battery, complete
113068	Water heating battery, complete
113550	Combined heating battery 500x400 left
113551	Combined heating battery 500x400 right
113552	Combined heating battery 600x400 left
113553	Combined heating battery 600x400 right
114127	Cooling battery 500x400 left
114128	Cooling battery 500x400 right
114129	Cooling battery 600x400 left
114130	Cooling battery 600x400 right
116482	Shunt valve KVS 0,4 3-way commercial
116483	Shunt valve KVS 1,0 3-way commercial
116484	Shunt valve KVS 1,6 3-way commercial
116485	Shunt valve KVS 2,5 3-way commercial
116486	Shunt valve KVS 4,0 3-way commercial
117209	Shunt valve KVS 6,3 3-way commercial
117860	Shunt valve KVS 10 3-way commercial
116487	Shunt valve KVS 0,4 2-way commercial
116488	Shunt valve KVS 1,0 2-way commercial
116489	Shunt valve KVS 1,6 2-way commercial
116490	Shunt valve KVS 2,5 2-way commercial
116491	Shunt valve KVS 4,0 2-way commercial
117208	Shunt valve KVS 6,3 2-way commercial
117859	Shunt valve KVS 10 2-way commercial
116492	Motor shunt valve 0-10V KVS ≤ 0,4
116493	Motor shunt valve on/off KVS ≤ 0,4
117207	Motor shunt valve 0-10V KVS ≥ 6,3



ProPanel



ProTouch



Filter



Closing air damper



Water heating battery



Electric heating battery



Combined heating battery

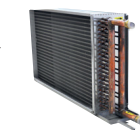

Cooling battery



Shuntventil 2-way



Motor shunt valve 0,4 - 4,0



Shuntventil 3-way



Motor shunt valve 6,3 - 10

Accessories, control system CS2500

112435	Modbus, communication module SP70
112438	BACnet IP, communication module
112439	Expansion module 14 IO
09368	Room sensor CC 1040
09369	Outdoor sensor CC 1041
09364	Press button
112442	Timer, electronic
112441	Timer, mechanical
09390	Motion detector SP 450
09358	Motion detector SP 435
09359	CO ₂ sensor SP440
09861	Smoke detector SP445
112444	Pressure sensor 0-1250 Pa



Modbus SP70



BACnet IP



Expansion module



Room sensor CC 1040



Outdoor sensor CC 1041



Press button



Timer electronic



Timer mechanical



Motion detector SP 450



CO₂ sensor SP 440



Smoke detector SP 445



Motion detector SP 435



Pressure sensor

For more information on topics including installation and wiring diagrams, see www.flexit.com

