

CONTENT:

FSB certified smoke extraction fan



www.exhausto.com

EXHAUSTO



Description

FSB smoke extraction fan

FSB smoke extraction fan is a box fan approved for temperatures up to 400°C for 120 min. FSB smoke extraction fan is approved as both a general operations fan and an evacuation fan in accordance with EN12101-3:2015.

As a general operations fan, FSB is a low-energy box fan, as it is fitted with an EC motor and fan impellers with backward curved blades. FSB is available in four sizes, covering the capacity range 350 - 7300 m³/h.

FSB smoke extraction fan

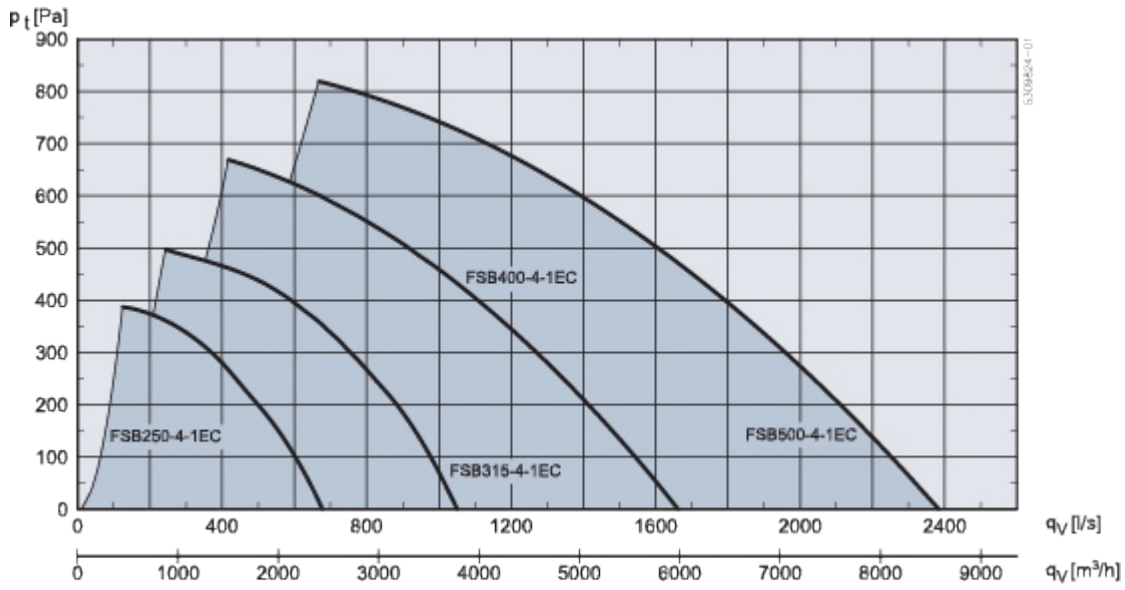

FSB smoke extraction fan

Design

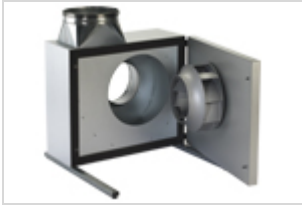

FSB smoke extraction fans are made from Aluzinc® AZ185 class C4 in accordance with EN/ISO12944-2 and insulated for sound and condensation with 50 mm mineral wool.

FSB can be ordered in a special version for temperatures right up to 200°C.

FSB has been tested and approved both as a general operations fan and as an evacuation fan F400/2h in accordance with EN12101-3:2015.

Fan impeller



The ventilator impeller is a B-impeller made from cast aluminium.

It has backward curved blades, thus ensuring low energy consumption and the further advantage that less dirt is attracted, with impaired impeller efficiency as a result.

Spigots



The spigots on FSB have rubber gaskets, with a transition piece on the extract side specially developed for minimum pressure drop.

Oscillation dampers



To minimise noise and vibration, the box ventilator is fitted as standard with efficient oscillation dampers mounted on brackets.

Split hinges

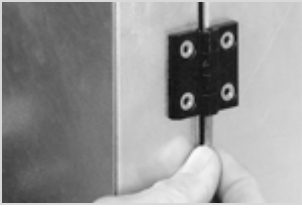

The FSB box fan has split hinges, which enable the door to be removed for installation and servicing, even in very confined conditions or for transport to difficult locations.

Condensation outlet

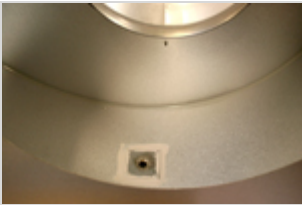

The FSB box fan is designed to transport air with an air humidity of less than 80% RH.

FSB is available as a special model with a condensation outlet for air with over 80% RH.

FSB smoke extraction fan

The FSB smoke extraction fan is a low-energy ventilator, in which ventilator housing, centrifugal impeller and motor all work together as one technology.

All FSB smoke extraction fan fulfil both the 2015 requirements laid down in the Ecodesign Directive EC327/2011 and those indicated as future 2020 requirements.

FSB smoke extraction fan

FSB smoke extraction fan are fitted with a single phase EC motor, directly connected to the fan impeller.

The EC motor for FSB is a permanent-magnet motor of class IE5 with motor control for 1 x 230 V or 3 x 400 V connection. The motor control and the motor are protected from overloading, blocking, over and under voltage, and over heating.

The motor control is factory programmed by EXHAUSTO for optimal operation of the ventilator. It only requires mains connection and a control signal from an EXHAUSTO EFC1P or MAC12 controller or a 0-10V signal.

The motor controls also provide a Modbus interface for fan control and alarm read-offs etc.

FSB smoke extraction fan

The smoke exhaust fan can be mounted in various positions. Note, however, that the ventilator must not be positioned with the motor turned downwards.

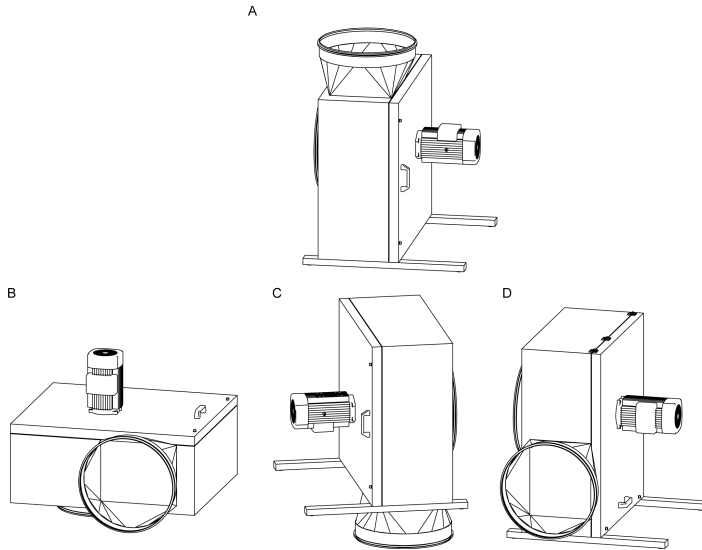
Standard installation: A**Alternative installation options B/C/D:**

During installation, consideration must be given to opening the door for servicing and to access to door screws (see dimensions table on pages 7 and 15 in the product instructions where opening radius R is given). There should also be enough space to insulate the ducts.

In installation options B and D, with the door facing upwards, special fittings must be used to hold the door (accessory).

The smoke extraction fan should not be screwed onto the supporting base. The base must be stable and vibration free, with no sagging. The outdoor model can be installed according to options A and B.

FSB smoke extraction fan

BFL Brandflex



BFL is made from steel-reinforced glass fabric, ceramic material and silica fibre.

BFL Brandflex satisfies the fire safety requirements for building components of materials class A2-s1,d0 in accordance with EN13501-1.

THA/THAV Roof terminal



Roof terminals THA and THAV are designed for air exhausts from EXHAUSTO box ventilators FSB, BESB and BESF.

THA is insulated for condensation and has a horizontal exhaust, while THAV is insulated for both sound and condensation and has a vertical exhaust.

More information on roof terminals.



Technical data, FSB250-4-1EC

FSB250-4-1EC

MODEL	FSB250-4-1EC
Fan data	
Max. overall efficiency	68,4%
ECO measurement set-up (A-D)	D
Efficiency requirements	64, N(2015)
ECO efficiency at optimal operating point	92,7
Motor	
Motor	EC motor with integral VSD
<u>Optimal operating point:</u>	
Absorbed power	164 W
Airflow	1354 m ³ /h
Total pressure	298 Pa
Rpm	1443 rpm
Nominal rpm (N)	1400 rpm
Electric supply (U)	1x230 V ~ 50 Hz
Overload protection	Integrated in motor control
Max absorbed current* (I)	1.2 A.
Max. absorbed power (P ₁)**	0.17 kW
Motor output (P ₂)**	0.18 kW
Other data	
Weight	52 kg

Conditions:

- * I is the maximum absorbed current throughout the control range - or the full load current if this is larger
- ** P_1 is the maximum absorbed power from the mains supply, where P_2 is the motor's nominal output.
- Stated data are for $t = 20^\circ\text{C}$
- Density = 1.2 kg/m^3
- Gas temperature: min. -12°C , max. $+80^\circ\text{C}$
- Ambient temperature: Max. $+40^\circ\text{C}$
- Pressure ratio: $< 1,11$
- other points in acc. with EC327/2011 - see product instructions

FSB250-4-1EC

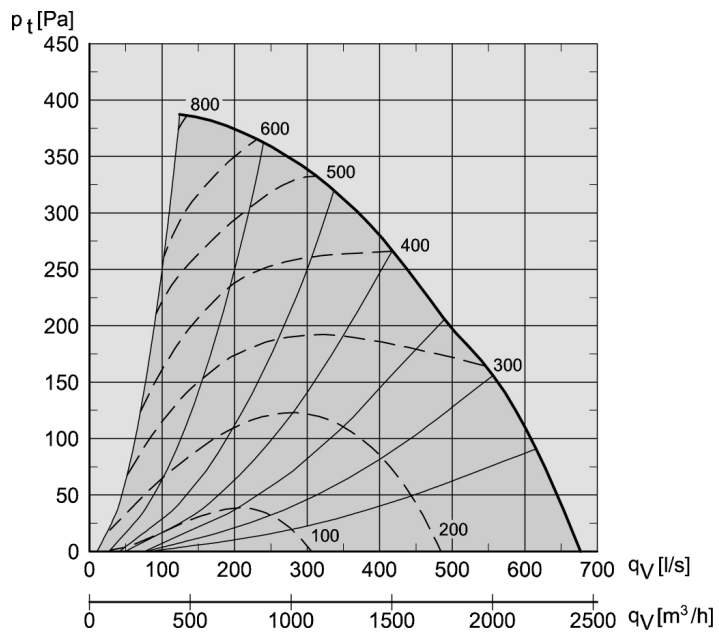

FSB250-4-1EC

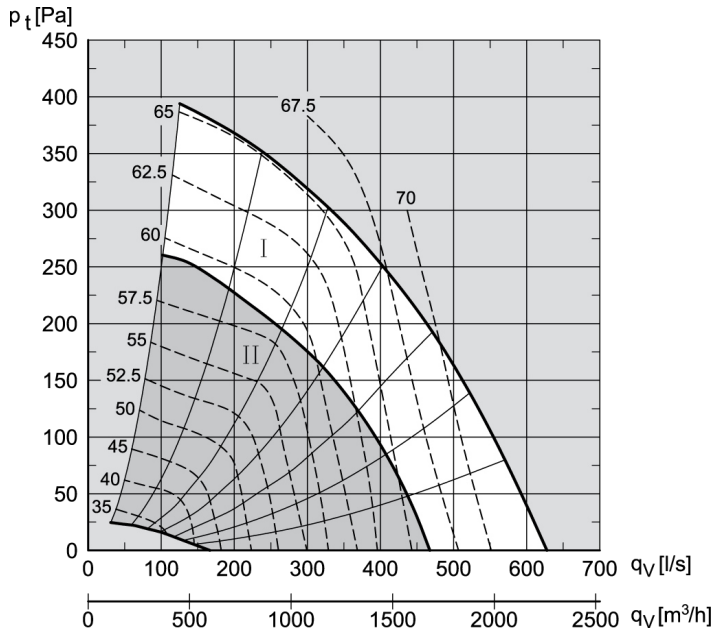

Hz	$K_{dB(A)}$		$K_w(dB)$								
	K_{wA}	K_{pA}	125		250		500	1K	2K	4K	8K
			I	II	I	II					
L_{w1}			8	11	6	3	-3	-11	-14	-22	-32
L_{w2}	2		5	10	8	5	-1	-5	-11	-19	-32
L_{w3}	-12		-10	-4	-12	-16	-13	-19	-20	-26	-33
L_{pA3}		-20									

FSB250-4-1EC

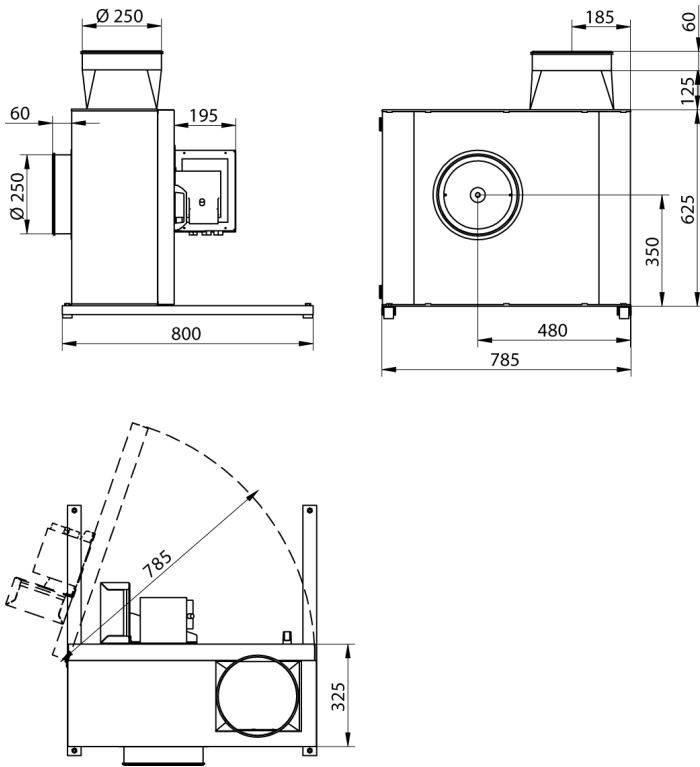

FSB250-4-1EC

Fire

FSB tolerates temperatures up to 80 °C in normal operation and up to 400 °C for 120 min. in case of fire.

Flue gas resistance

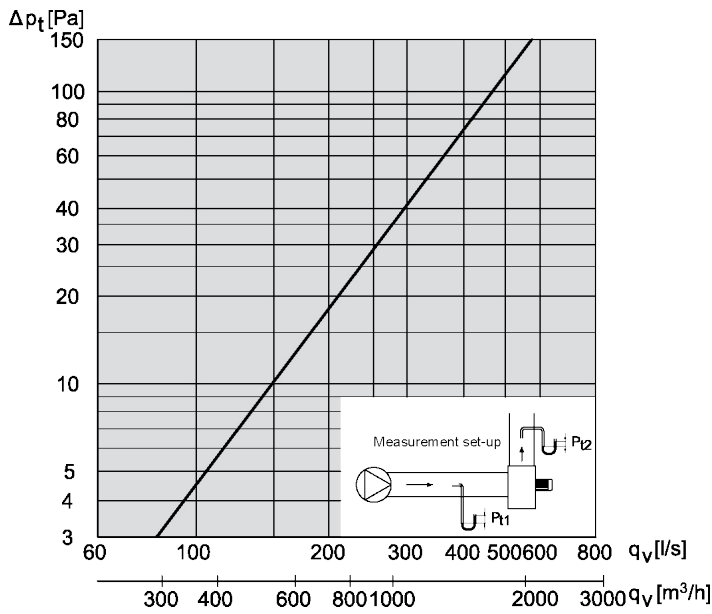



Technical data, FSB315-4-1EC

FSB315-4-1EC

MODEL	FSB315-4-1EC
Fan data	
Max. overall efficiency	69,0 %
ECO measurement set-up (A-D)	D
Efficiency requirements	64, N(2015)
ECO efficiency at optimal operating point	89,7
Motor	
Motor	EC motor with integral VSD
<u>Optimal operating point:</u>	
Absorbed power	335 W
Airflow	2173 m ³ /h
Total pressure	383 Pa
Rpm	1417 rpm
Nominal rpm (N)	1400 rpm
Electric supply (U)	1x230 V ~ 50 Hz
Overload protection	Integrated in motor control
Max absorbed current* (I)	2.2 A
Max. absorbed power (P ₁)**	0.35 kW
Motor output (P ₂)**	0.37 kW
Other data	
Weight	57 kg

Conditions:

- * I is the maximum absorbed current throughout the control range - or the full load current if this is larger
- ** P₁ is the maximum absorbed power from the mains supply, where P₂ is the motor's nominal output.
- Stated data are for t = 20°C

- Density = 1.2 kg/m³
- Gas temperature: min. -12°C, max. +80° C
- Ambient temperature: Max. +40° C
- Pressure ratio: < 1,11
- other points in acc. with EC327/2011 - see product instructions

BESB315-4-1EC

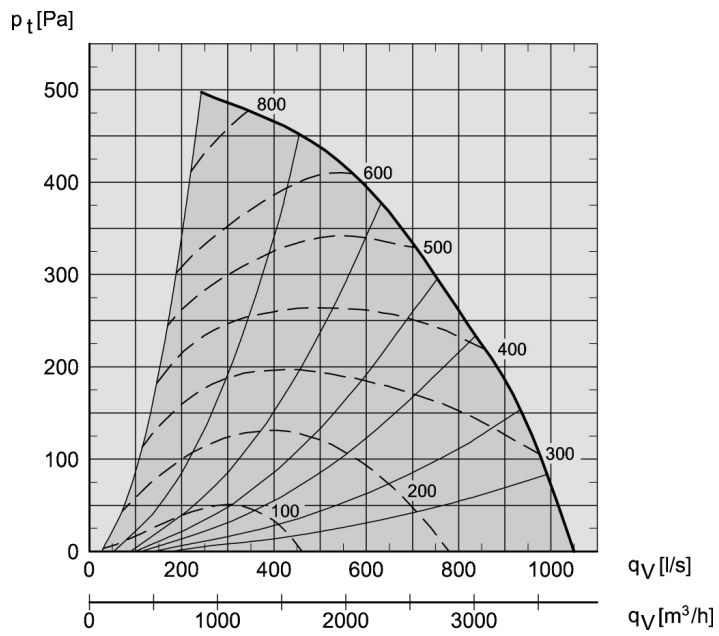

FSB315-4-1EC

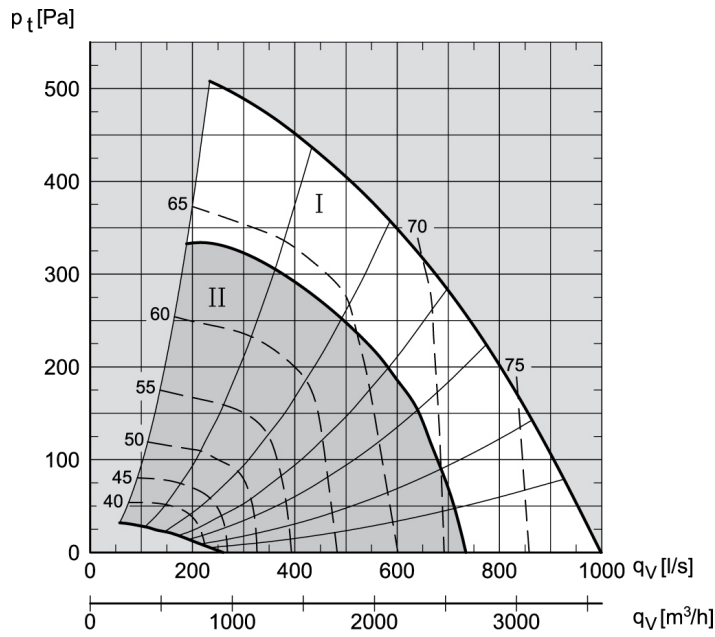

	$K_{[dB(A)]}$		$K_{w[dB]}$								
	K_{wA}	K_{pA}	125		250		500	1K	2K	4K	8K
			I	II	I	II	Hz	Hz	Hz	Hz	Hz
L_{w1}			0	6	5	1	-3	-5	-10	-17	-25
L_{w2}	4		1	7	8	4	-3	2	-7	-15	-25
L_{w3}	-15		-10	-4	-11	-15	-19	-22	-23	-29	-34
L_{pA3}		-23									

FSB315-4-1EC

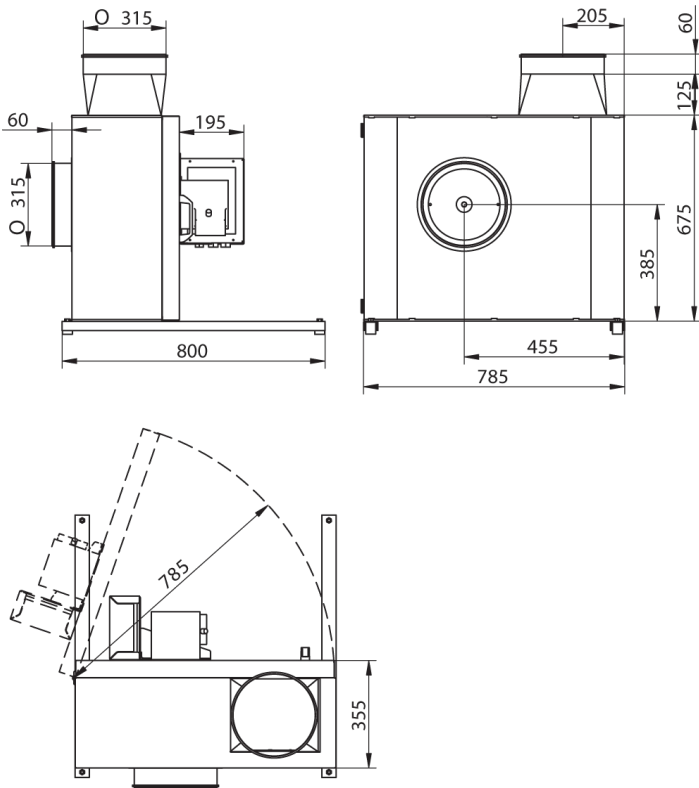

FSB315-4-1EC

Fire

FSB tolerates temperatures up to 80 °C in normal operation and up to 400 °C for 120 min. in case of fire.

Flue gas resistance

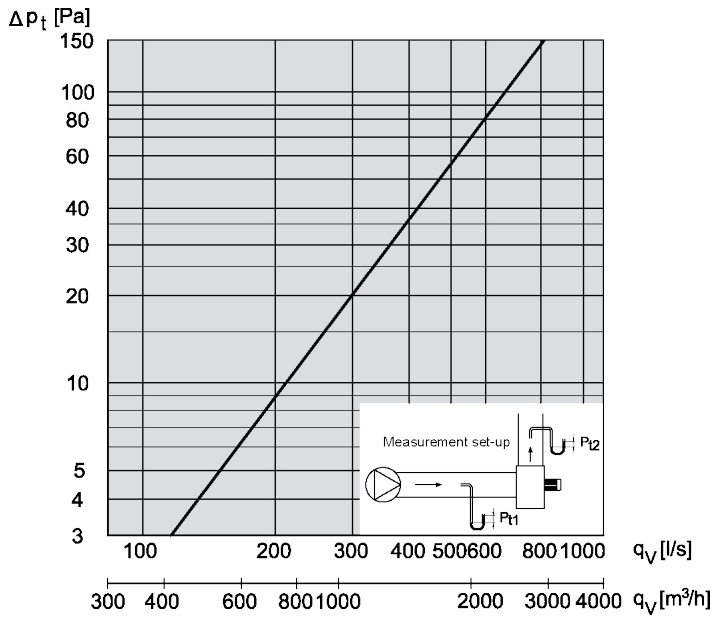



Technical data

FSB400-4-1EC

MODEL	FSB400-4-1EC
Fan data	
Max. overall efficiency	71,6 %
ECO measurement set-up (A-D)	D
Efficiency requirements	64, N(2015)
ECO efficiency at optimal operating point	91,7
Motor	
Motor	EC motor with integral VSD
<u>Optimal operating point:</u>	
Absorbed power	375 W
Airflow	2868 m ³ /h
Total pressure	337 Pa
Rpm	1195 rpm
Nominal rpm (N)	1435 rpm
Electric supply (U)	1x230 V ~ 50 Hz
Overload protection	Integrated in motor control
Max absorbed current* (I)	4.5 A
Max. absorbed power (P ₁)**	0.67 kW
Motor output (P ₂)**	0.75 kW
Other data	
Weight	73 kg

Conditions:

- * I is the maximum absorbed current throughout the control range - or the full load current if this is larger
- ** P₁ is the maximum absorbed power from the mains supply, where P₂ is the motor's nominal output.
- Stated data are for t = 20°C
- Density = 1.2 kg/m³

- Gas temperature: min. -12°C, max. +80° C
- Ambient temperature: Max. +40°C
- Pressure ratio: < 1.11
- other points in acc. with EC327/2011 - see product instructions

BESB400-4-1EC

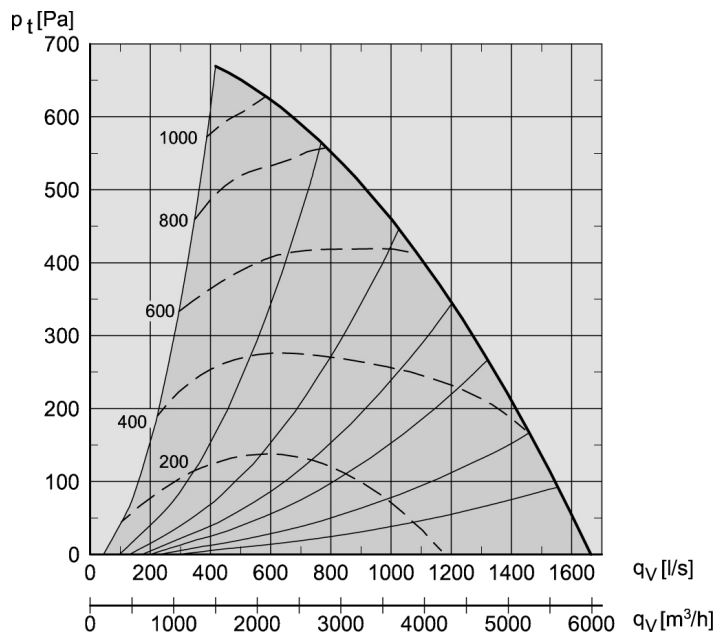

FSB400-4-1EC

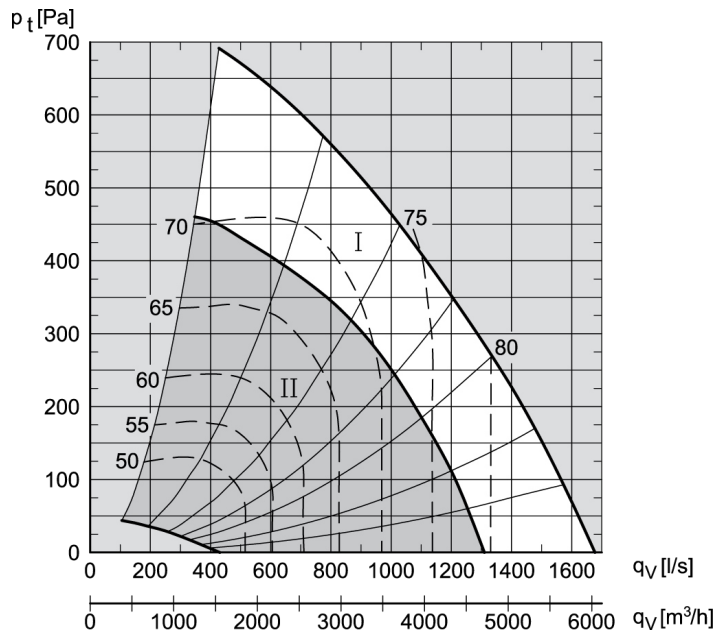

	$K_{[dB(A)]}$		$K_w[dB]$								
	K_{WA}	K_{PA}	125		250		500	1 k	2 k	4 k	8 k
			I	II	I	II	Hz	Hz	Hz	Hz	Hz
L_{w1}			0	6	4	0	-4	-4	-11	-17	-28
L_{w2}	4		0	6	6	2	-3	2	-10	-18	-30
L_{w3}	-17		-13	-7	-14	-18	-21	-24	-28	-31	-37
L_{pA3}		-25									

FSB400-4-1EC

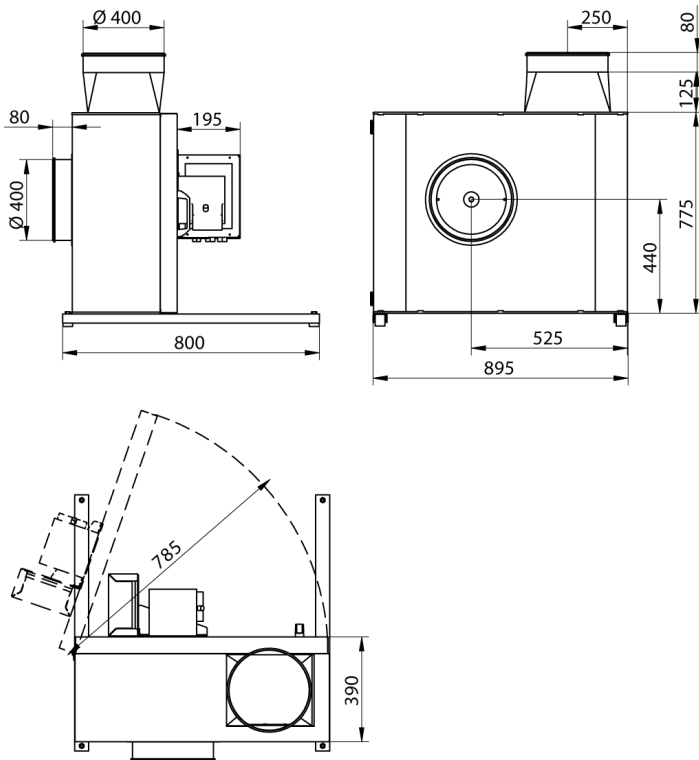

BESB400 Spilt version

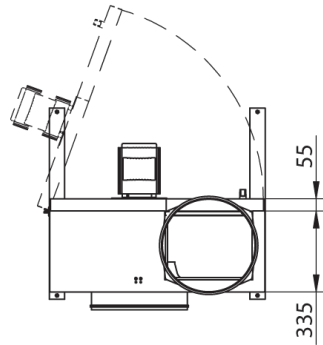
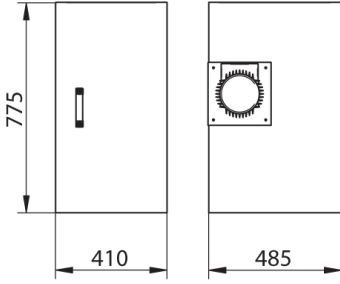
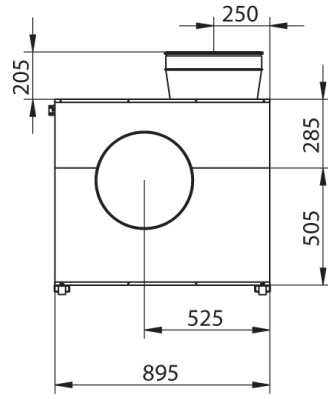
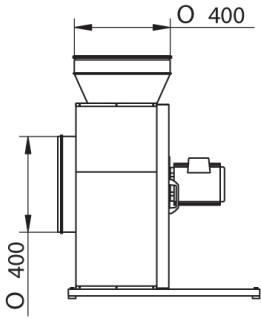

FSB400-4-1EC

Fire

FSB tolerates temperatures up to 80 °C in normal operation and up to 400 °C for 120 min. in case of fire.

Flue gas resistance

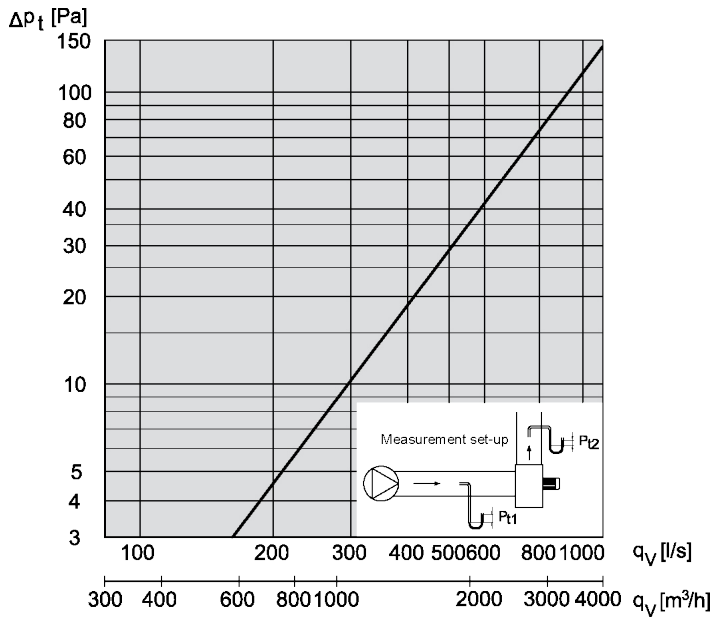



Technical data, FSB500-4-1EC

FSB500-4-1EC

MODEL	FSB500-4-1EC
Fan data	
Max. overall efficiency	71,5 %
ECO measurement set-up (A-D)	D
Efficiency requirements	64, N(2015)
ECO efficiency at optimal operating point	87,4
Motor	
Motor	EC motor with integral VSD
<u>Optimal operating point:</u>	
Absorbed power	824 W
Airflow	4252 m ³ /h
Total pressure	499 Pa
Rpm	1261 rpm
Nominal rpm (N)	1420
Electric supply (U)	1x230 V ~ 50 Hz
Overload protection	Integrated in motor control
Max absorbed current* (I)	8.5 A
Max. absorbed power (P ₁)**	1.23 kW
Motor output (P ₂)**	1.1 kW
Other data	
Weight	88 kg

Conditions:

- * I is the maximum absorbed current throughout the control range - or the full load current if this is larger
- ** P₁ is the maximum absorbed power from the mains supply, where P₂ is the motor's nominal output.
- Stated data are for t = 20°C

- Density = 1.2 kg/m³
- Gas temperature: min. -12°C, max. +80° C
- Ambient temperature: Max. +40°C
- Pressure ratio: < 1.11
- other points in acc. with EC327/2011 - see product instructions

FSB500-4-1EC

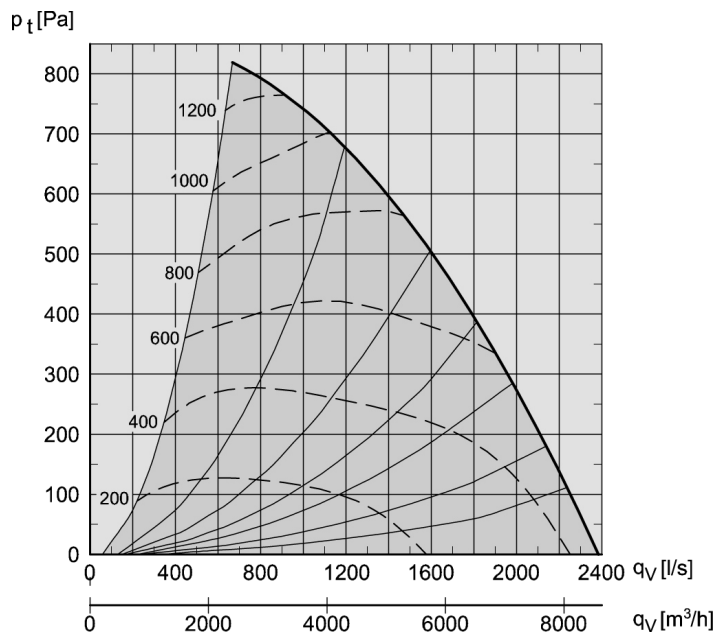

BESB500-4-3

FSB500-4-1EC

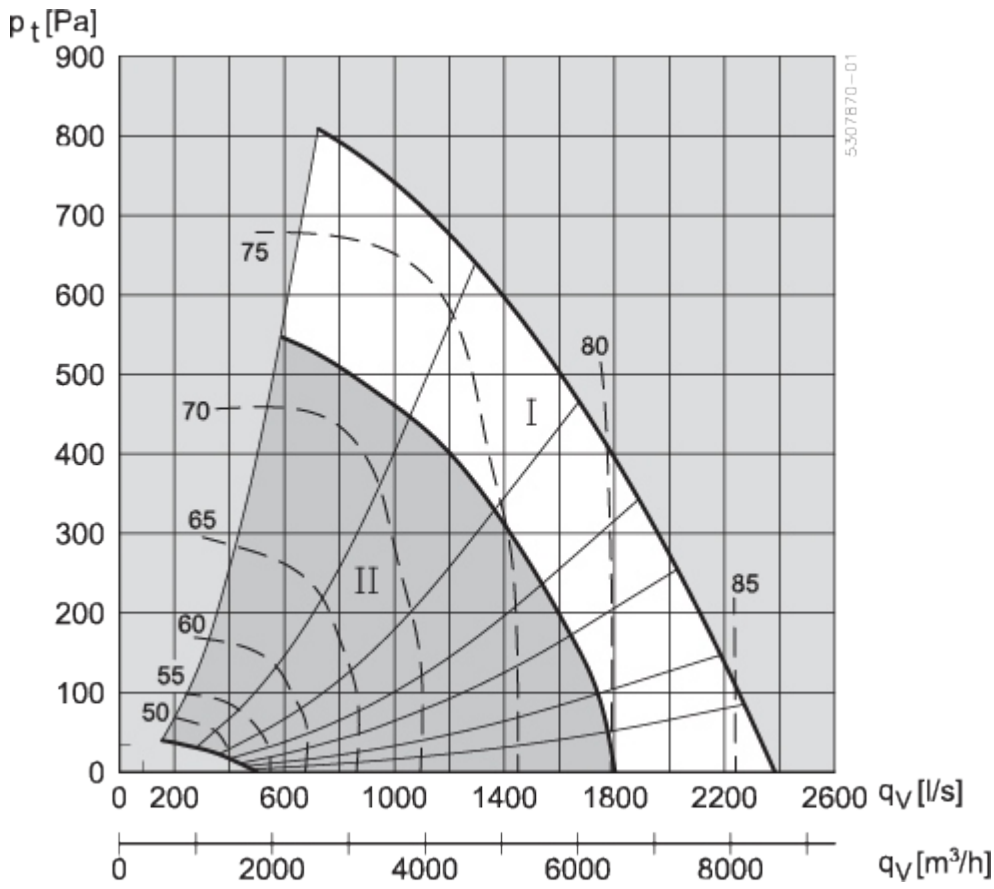

	$K_{[dB(A)]}$		$K_w[dB]$								
	K_{wA}	K_{pA}	125		250		500	1 k	2 k	4 k	8 k
			I	II	I	II	Hz	Hz	Hz	Hz	Hz
L_{w1}			1	7	4	0	-3	-4	-12	-15	-24
L_{w2}	6		1	7	8	4	-1	4	-11	-16	-28
L_{w3}	-15		-13	-7	-11	-15	-18	-21	-25	-27	-33
L_{pA3}		-25									

FSB500-4-1EC

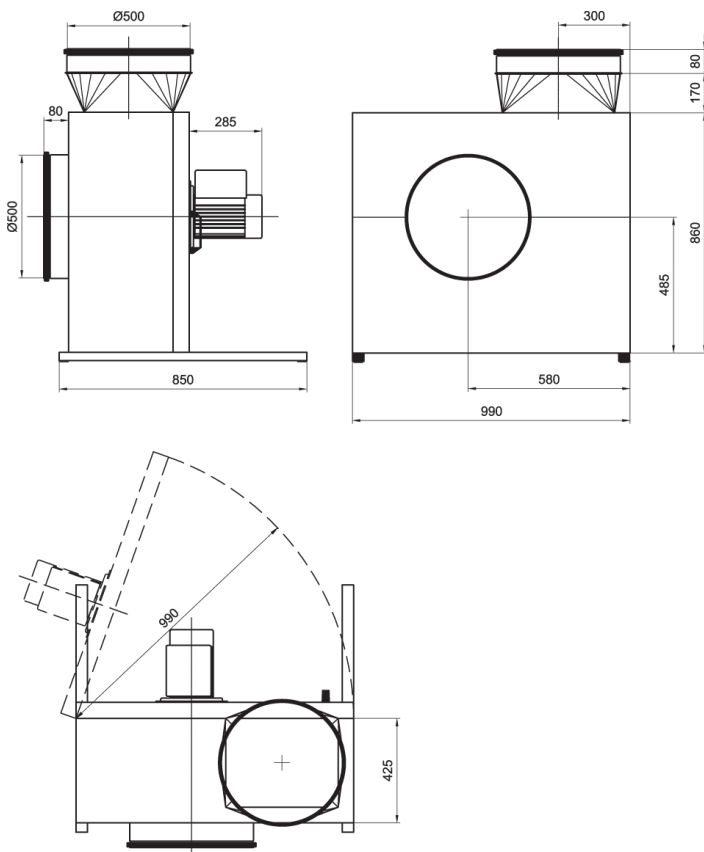

FSB500-4-1EC

Fire

FSB tolerates temperatures up to 80 °C in normal operation and up to 400 °C for 120 min. in case of fire.

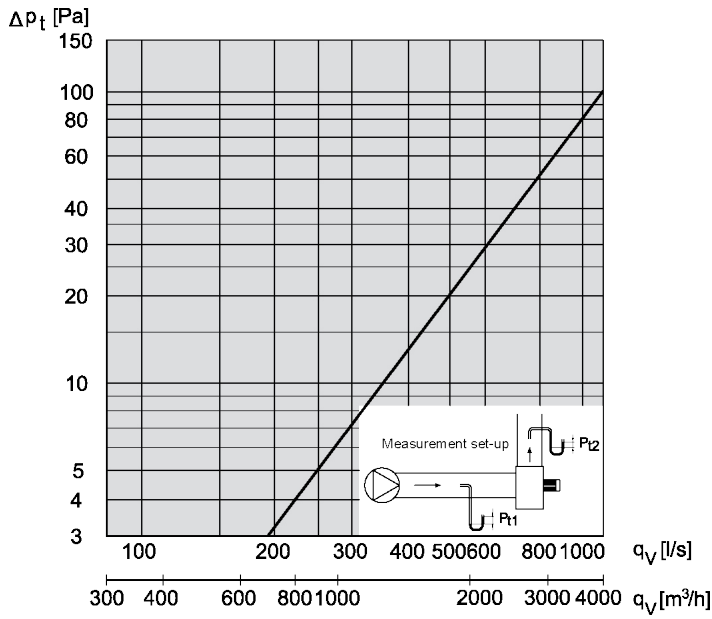

EXHAUSTO

Your ventilation expert and professional business partner

At EXHAUSTO we never compromise on quality, and since we are experts in ventilation with many years of specialised experience, you can be assured of not just the best ventilation solution but also a competent business partner.

EXHAUSTO develops and manufactures high-quality products and systems for comfort ventilation in all areas of use – from offices, shops, schools and institutions to industrial buildings, hotels and hospitals. With a focus on high efficiency ratings and an energy consumption which sets new industry standards, EXHAUSTO is one of the absolute leaders of the field.



www.exhausto.com

EXHAUSTO, Export
Odensevej 76
DK-5555 Langeskov

EXHAUSTO